

1/48 SCALE PLASTIC KIT

ProfiPACK
edition

#82151



INTRO

By the early 30s the Royal Air Force (RAF) was looking for replacement of its ageing biplane fighters like Hawker Fury was. The need of considerably faster aircraft was obvious, as the racing monoplane floatplanes of that time, fighting for famous Schneider Trophy, reached about twice the speed of the Fury. One of than most successful designers of the racing floatplanes was Reginald J. Mitchell. His best creation, the Supermarine S.6B, raised the world speed record to 407mph (655km/h) on September 20th, 1931 and British Air Ministry, under influence of such an achievement, issued the Specification F.7/30 in October 1931, calling for modern pursuit airplane capable of at least 250mph (400km/h) of maximum speed. Quite contrary to the demand, seven out of eight entries were again biplanes. The only monoplane proposal was Mitchell's Supermarine 224, but the design with a gull wing, fixed undercarriage and Rolls-Royce Goshawk engine was a disappointment in many areas, maximum speed being one of them. The Gloster Gladiator biplane was declared the winner and RAF had to wait for its monoplane fighters a little bit longer...

From disillusion to success

The fiasco with The Type 224 did not prevent Mitchell from further work. Instead of developing the 224 he persuaded the Supermarine company to fund the completely new design of Type 300, using brand new Rolls-Royce PV12 engine, later known as the Merlin. The Air Ministry expressed interest and issued Specification F.37/34 on December 28th, 1934 to fund the prototype armed with four guns. By early April 1935 Mitchell received the detail of Specification F.10/35, calling for eight guns instead. The change was possible, but only on cost of bomb provision removal and reduction of the overall capacity of the fuel tanks. The decision caused the so called "short legs" of the Spitfire, meaning a lack of range and endurance.

The Type 300 performed its maiden flight on March 5th, 1936. The K5054 prototype took off from the Eastleigh Aerodrome with chief test pilot Captain Joseph "Mutt" Summers at controls. After some eight minutes the pilot was so impressed, he reportedly said: "Do not change a thing!". In July 1936 the prototype completed its initial trials at Martlesham Heath successfully and during December it conducted further trials now with its full weaponry of eight 0,303in (7,7mm) Browning machine guns installed. During March 1937 the problem with the armament emerged, as the guns were freezing at high altitude. It took until October 1938 to introduce effective system of gun-heating, using the hot air from enlarged starboard underwing radiator. The modification was incorporated from 60th produced Mk. I and retrofitted to the earlier airplanes.

To the service

Initial contract for 310 Spitfires was signed in June 1936 and the first unit to receive the new fighters (during August 1938) was No. 19 Squadron at Duxford. At the time the Great Britain entered the war with Germany (September 3rd, 1939), the RAF had already taken delivery of 306 Spitfires serving with eleven squadrons and by the beginning of May 1940 a further eight squadrons were added. Unfortunately, Reginald Mitchell did not live to see the Spitfire serving with the RAF units, as he died on June 11th, 1937 at the age of 42. The burden of the Spitfire development was on Joe Smith afterwards. It is fair to say the production of Spitfire was far from smooth, especially due to complex design of its elliptical wing, so several subcontractors were to help to fulfil the orders.

The first dogfight between Messerschmitt Bf 109s and Spitfire Mk. Is took place near Calais on May 23rd, 1939, but the first aerial victory over an enemy for Spitfire had to wait until October 16th, 1939, when nine Junkers Ju 88s attacked Royal Navy warships in the Firth of Forth. Two of them were shot down by pilots from Nos. 602 and 603 Squadrons. Half a year later the German forces launched their offensive in the West Europe and the Spitfires started to fire their guns in anger much more frequently with the glory time coming when famous Battle of Britain broke out in July 1940. Although the pursuit burden of the Battle was mainly on more numerous Hawker Hurricane, the Spitfire become an icon during the Battle, as it helped RAF Fighter Command to equal force with Luftwaffe's Bf 109s. During the period, some shortcomings emerged, firepower being one of them. It was believed during mid-30s that eight small calibre guns were the best arrangement, but the war experience proved it inadequate against multi engine bombers with self-sealing fuel tanks.

Constant development

The development of Spitfire was ongoing process from early stage of its service. One of the first major upgrades was change from ineffective two blade fixed-pitch wooden propeller to three-bladed two-pitch metal one starting from 78th production aircraft (and retrofitted to the earlier ones). The move increased the maximum speed, raised the ceiling, and shortened the take-off run. Starting from May 1939 the Spitfire Mk. Is changed the power unit, switching from Rolls-Royce Merlin II to Merlin III with the same power 1030hp (768kW) but with reliability improvements, allowing the installation of constant speed Rotol propeller. That not only gave the Spitfire, now marked Mk.Ia, improvement in rate of climb, but also made it easier to control. Starting from the early 1939 the Spitfires received new semi-bubble canopy improving the pilot's view. The early Spitfires had simple ring-and-bead gunsight, starting from September 1939 the GM2 reflector gunsights were fitted.

A very important issue was the armour, as the early production Spitfires had none. As a first measure the laminated glass was added to the windscreen. After that, the upper fuel tank received 3mm thick cover of light alloy, while lower one was protected by the Linatex sandwich (rubber and canvas). More to it, the steel plate was fitted behind the seat to protect pilot. The armouring added some weight. The first production Spitfire Mk.I was 5,819lb (2639kg), reaching top speed of 362mph (583km/h). In the summer of 1940 the weight of fully modified Mk.I rose to the 6150lb (2789kg) and the maximum speed decreased to 350mph (563km/h). But despite that the later aircraft were better fighters than the early ones. All in all, apart from the rather inadequate firepower for the time and some other shortages addressed on the fly, the Spitfire Mk.I proved to be extremely valuable fighter. There were 1,567 of all Mk.Is built. This model represents Mk.Ia marks and offers the parts for aircraft in several stages of its development.

ATTENTION



UPOZORNĚNÍ



ACHTUNG



ATTENTION



注意



Carefully read instruction sheet before assembling. When you use glue or paint, do not use near open flame and use in well ventilated room. Keep out of reach of small children. Children must not be allowed to suck any part, or pull vinyl bag over the head.



Před započítím stavby si pečlivě prostudujte stavební návod. Při používání barev a lepidel pracujte v dobře větrané místnosti. Lepidla ani barvy nepoužívejte v blízkosti otevřeného ohně. Model není určen malým dětem, mohlo by dojít k požití drobných dílů.

INSTRUCTION SIGNS

* INSTR. SYMBOLS

* INSTRUKTION

* SINNBILDEN

* SYMBOLES

* 記号の説明

OPTIONAL
VOLBABEND
OHNOUTSAND
BROUSITOPEN HOLE
VYVRTAT OTVORSYMETRICAL ASSEMBLY
SYMETRICKÁ MONTÁŽREMOVE
ODŘÍZNOUTREVERSE SIDE
OTOČITAPPLY EDUARD MASK
AND PAINT
POUŽIT EDUARD MASK
NABARVIT

PARTS



DÍLY



TEILE



PIÈCES



部品

PLASTIC PARTS

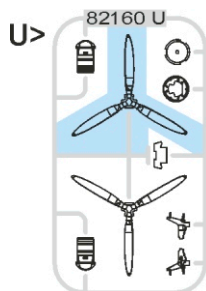
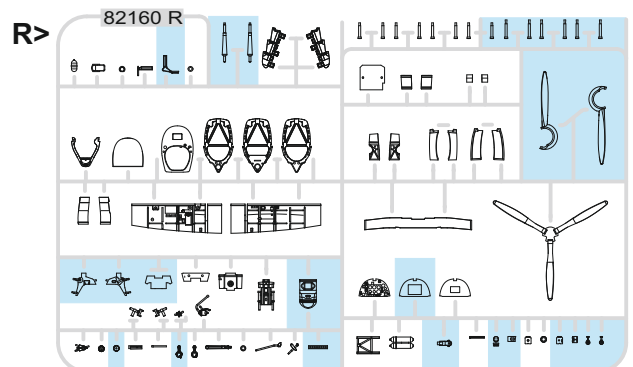
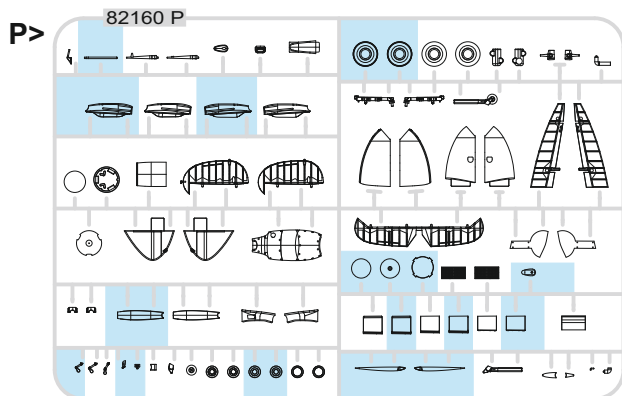
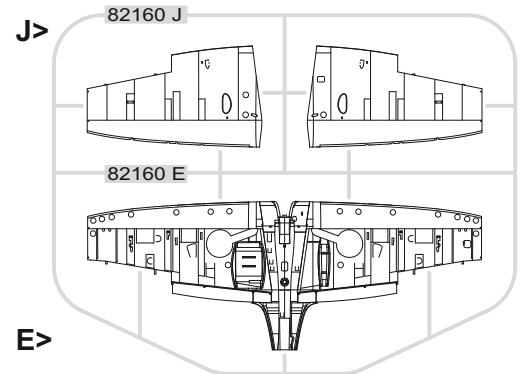
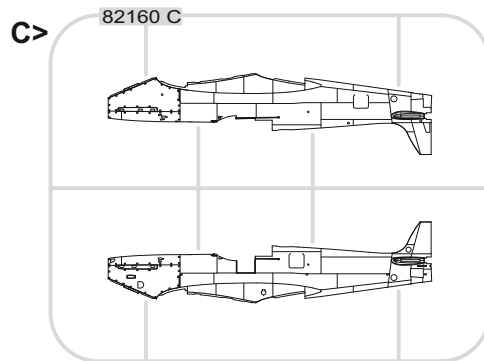
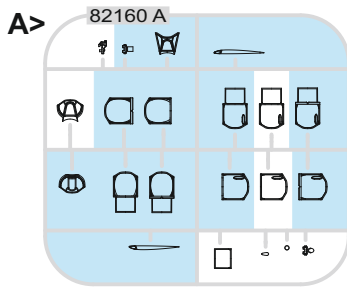

PE - PHOTO ETCHED DETAIL PARTS

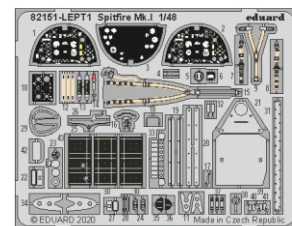

-Parts not for use. -Teile werden nicht verwendet. -Pièces à ne pas utiliser. -Tyto díly nepoužívejte při stavbě. - 使用しない部品

COLOURS



BARVY



FARBEN



PEINTURE



色

GSI Creos (GUNZE)		MISSION MODELS	
AQUEOUS	Mr.COLOR	PAINTS	
H3	C3	MMP-003	RED
H4	C4	MMP-007	YELLOW
H8	C8		SILVER
H11	C62	MMP-001	FLAT WHITE
H12	C33	MMP-047	FLAT BLACK
H51	C11	MMP-063	LIGHT GULL GRAY
H72	C369	MMP-078	DARK EARTH
H74	C368	MMP-080	SKY
H77	C137	MMP-040	TIRE BLACK
H90	C47		CLEAR RED
H94	C138		CLEAR GREEN

GSI Creos (GUNZE)		MISSION MODELS	
AQUEOUS	Mr.COLOR	PAINTS	
H330	C361	MMP-077	DARK GREEN
H331	C331		DARK SEAGRAY
H335	C363	MMP-094	MEDIUM SEAGRAY
H417	C117	MMP-051	LIGHT BLUE
H423	C123	MMP-054	DARK GREEN
	C26	MMP-080	DUCK EGG GREEN
	C364	MMP-079	AIRCRAFT GRAY-GREEN
Mr.METAL COLOR		METALLICS	
	MC214	MMM-001	DARK IRON
	MC218	MMM-003	ALUMINIUM

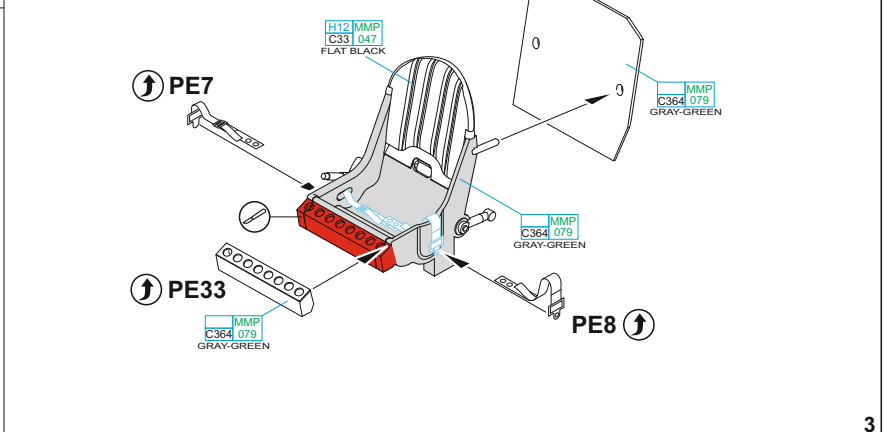
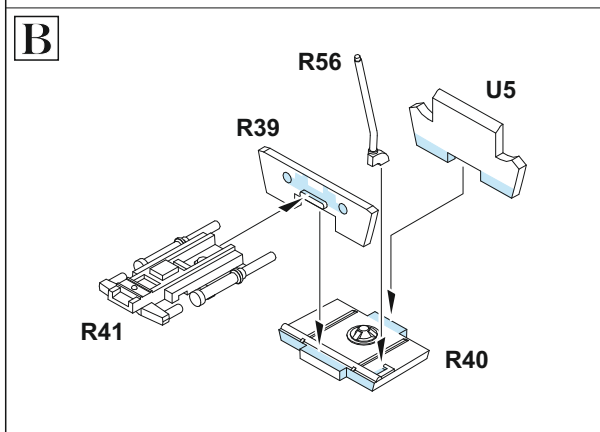
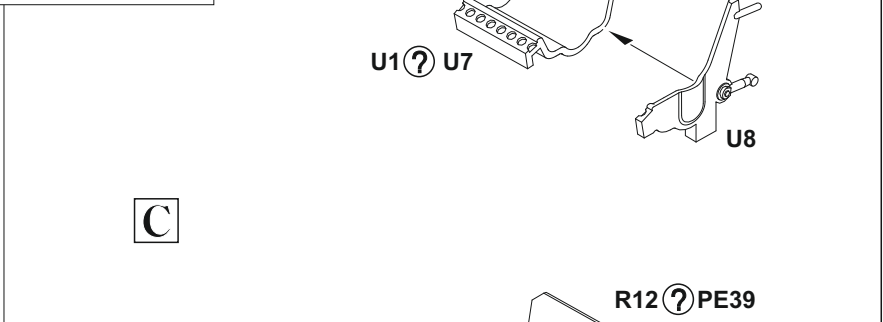
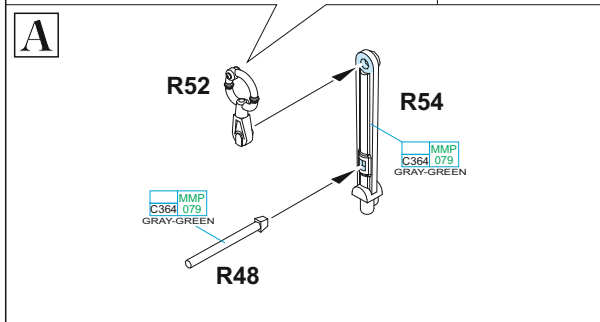
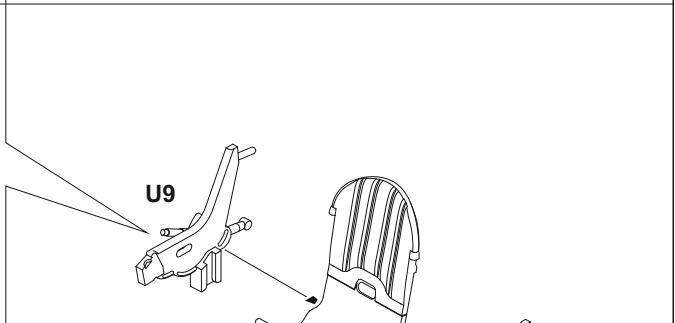
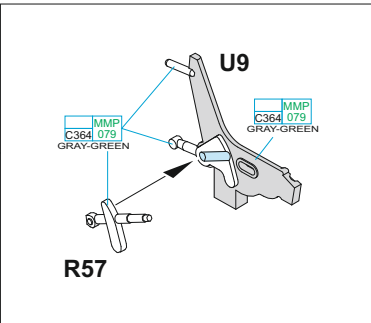
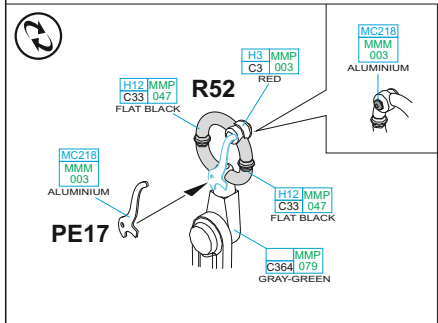
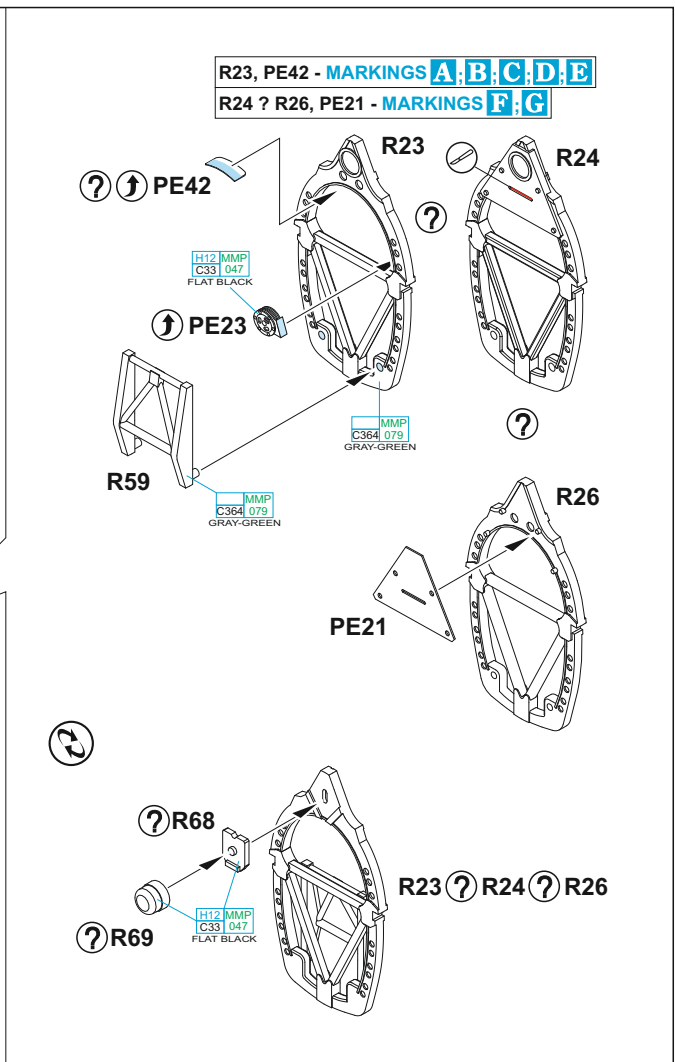
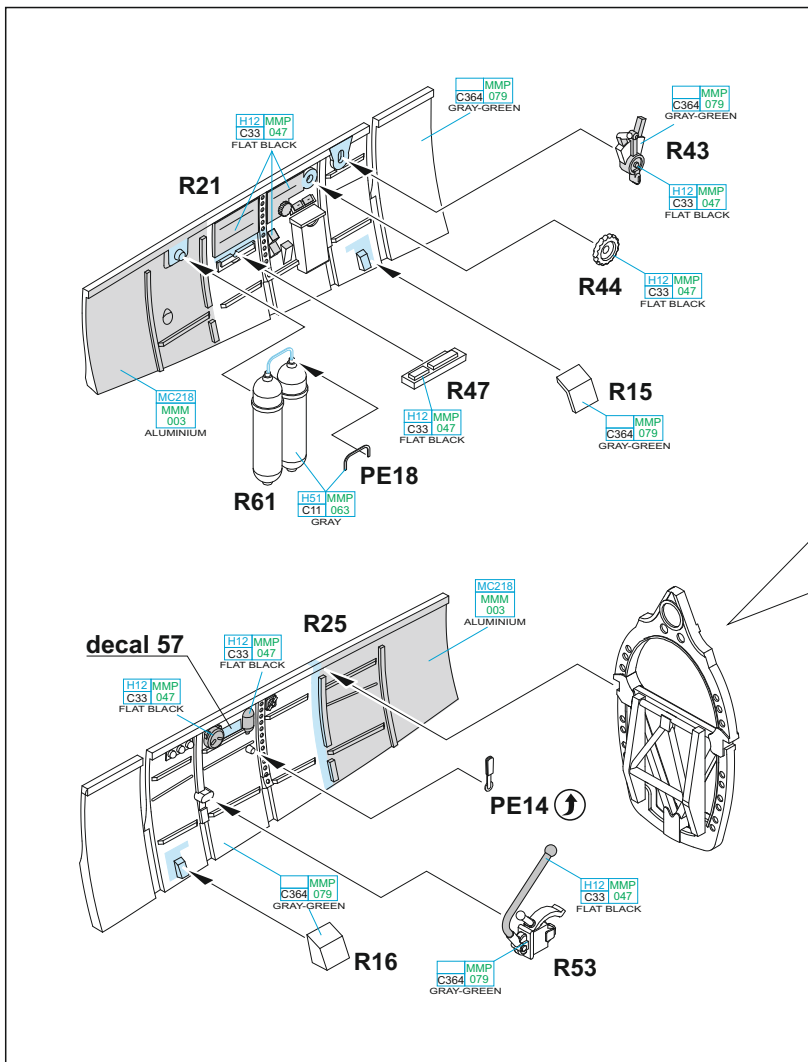

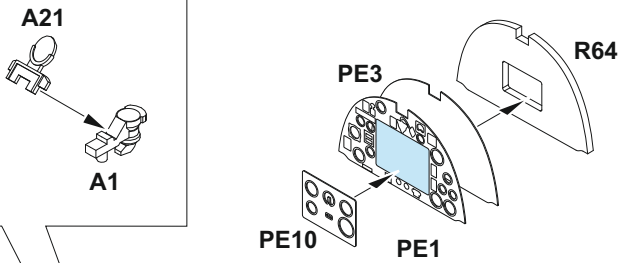
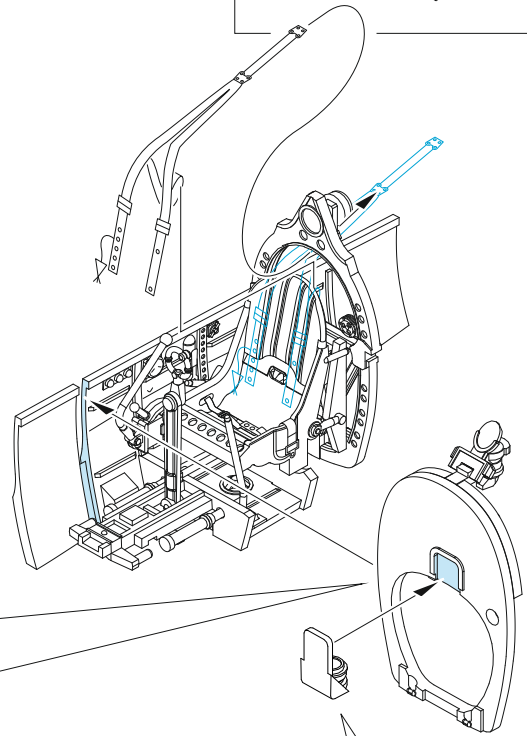
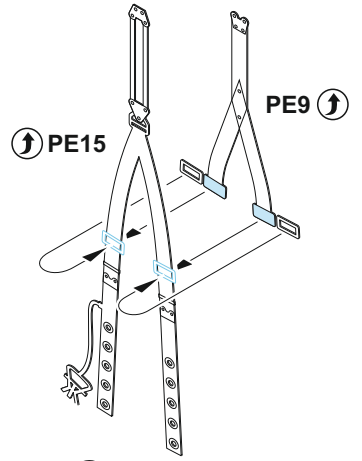
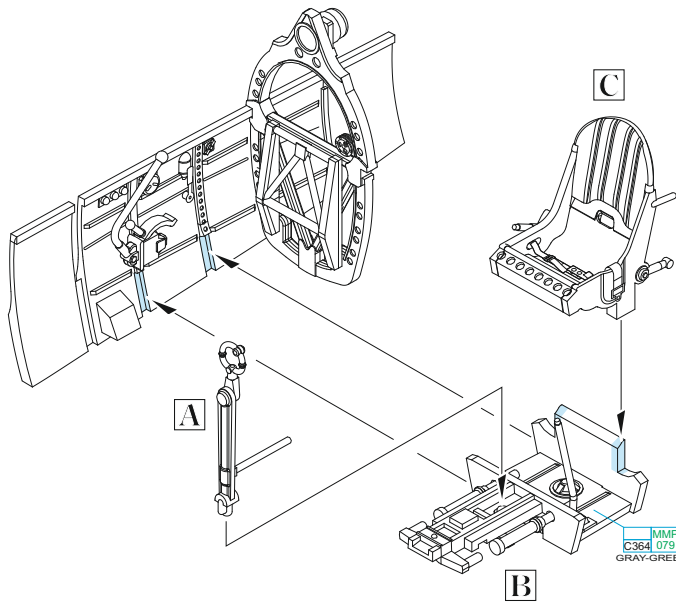

OPTIONAL: decal 50, 51, 52

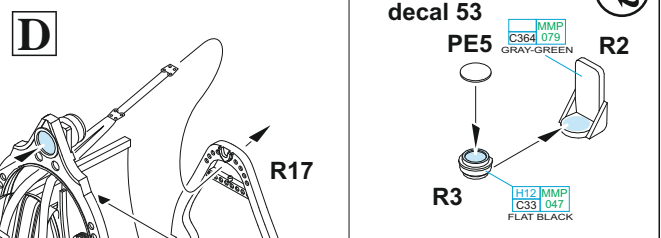
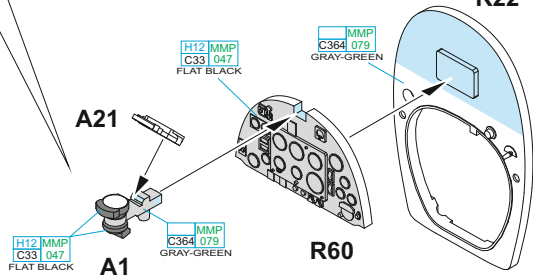

OPTIONAL: decal 53

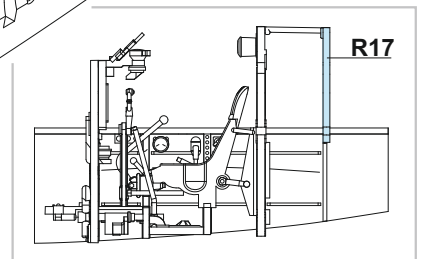
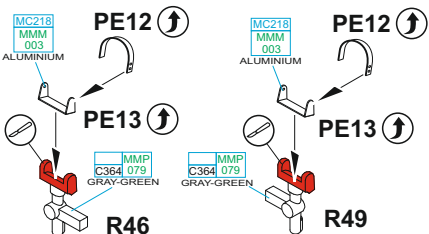
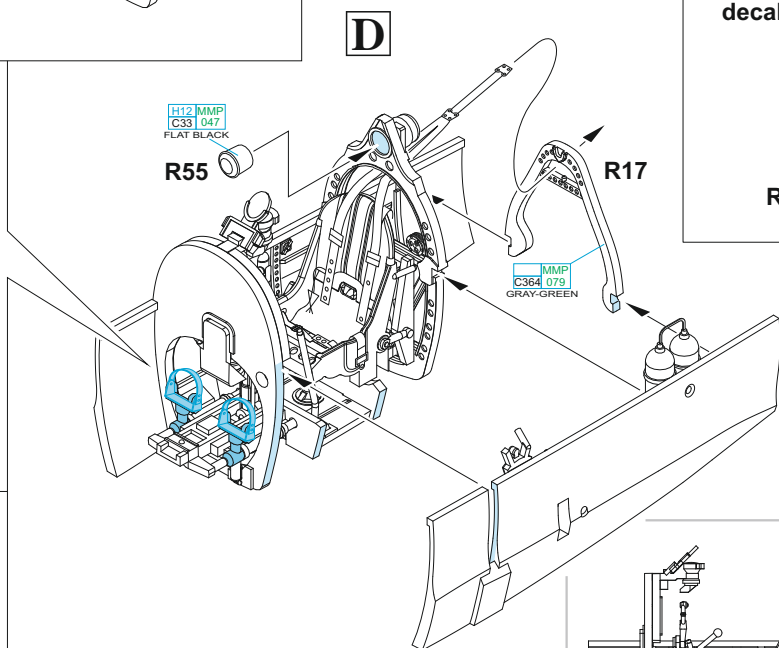
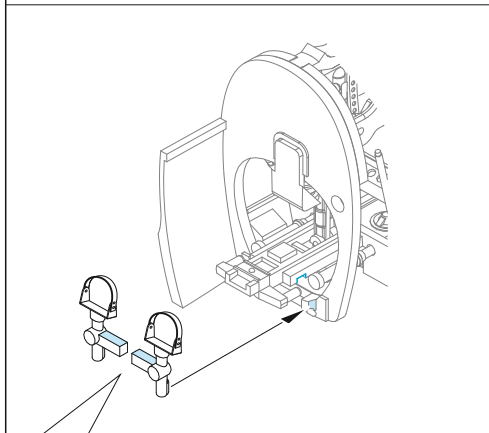

7 FOR CLOSED CANOPY ONLY

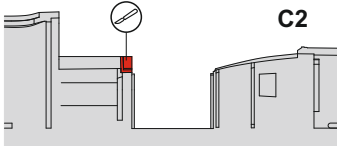

C2

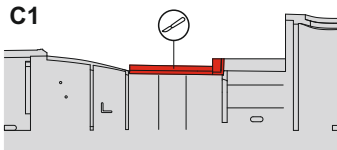

C1

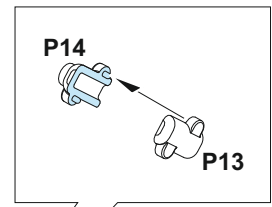
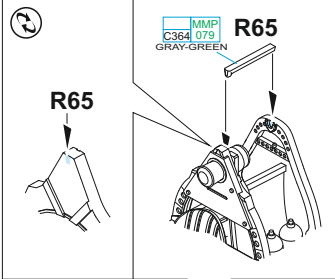

P14

P13

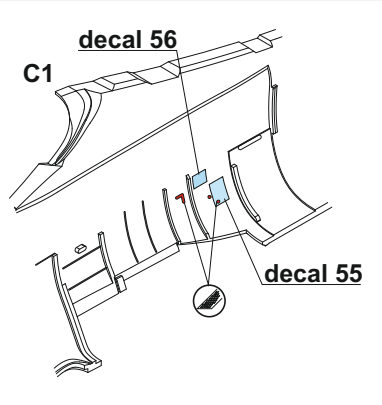
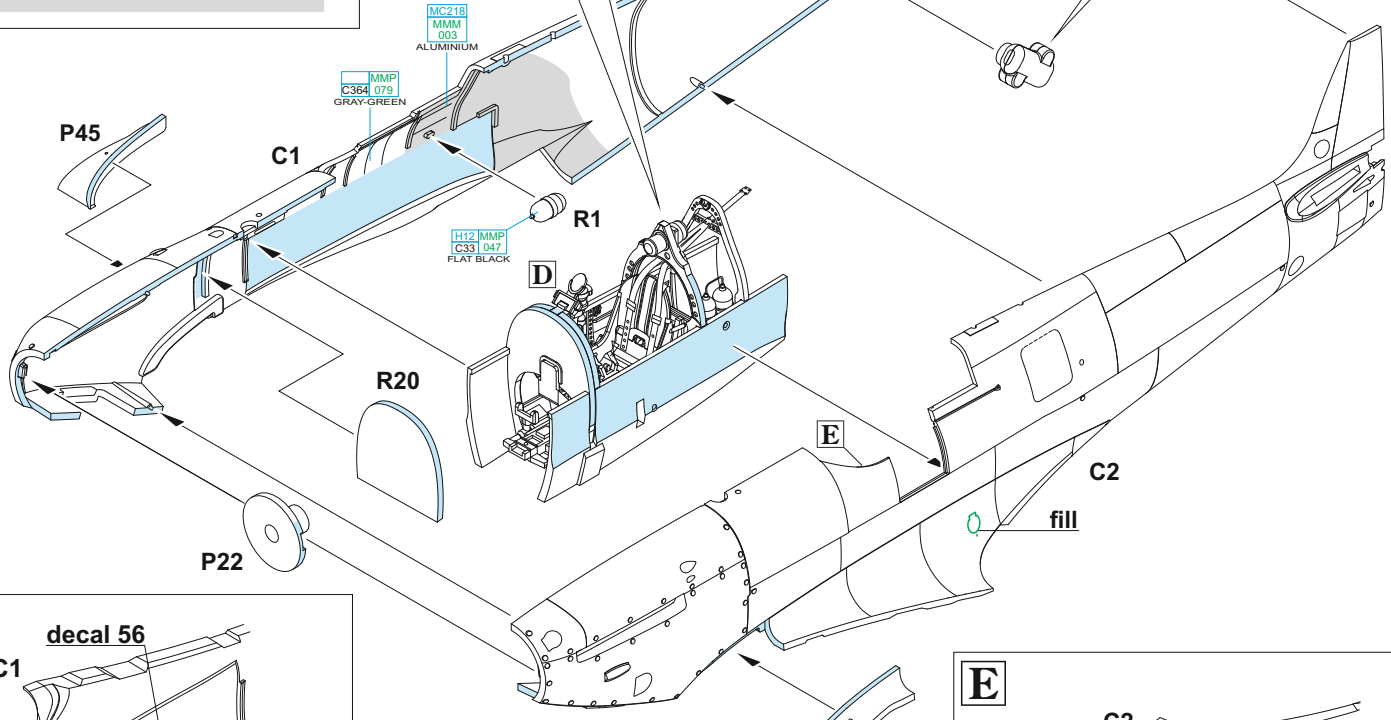

decal 56

decal 55

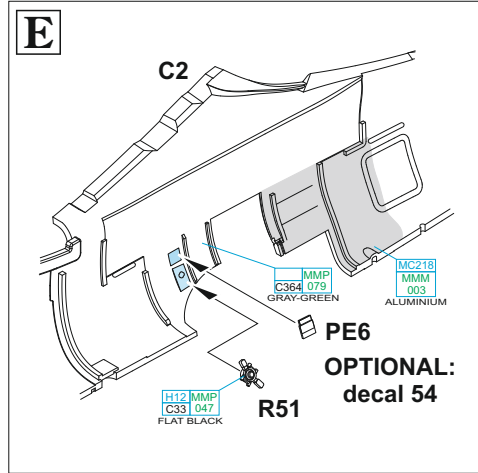

E

OPTIONAL:
decal 54

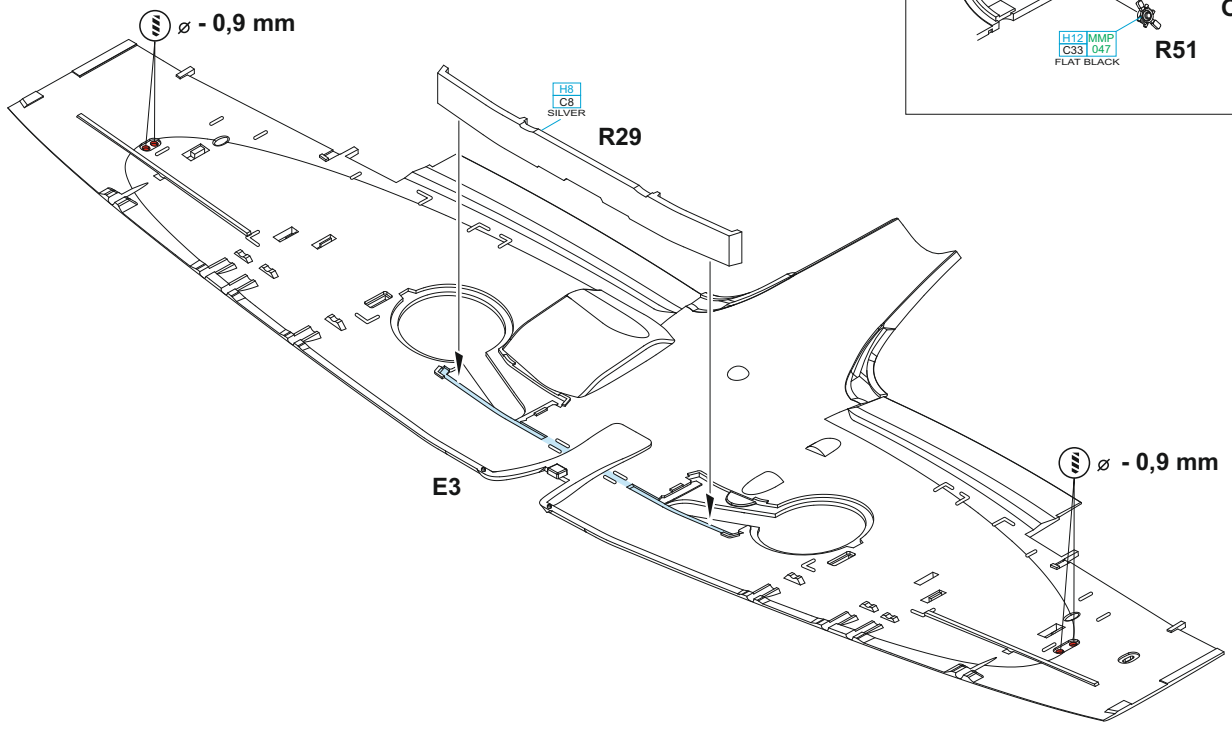

R29

E3

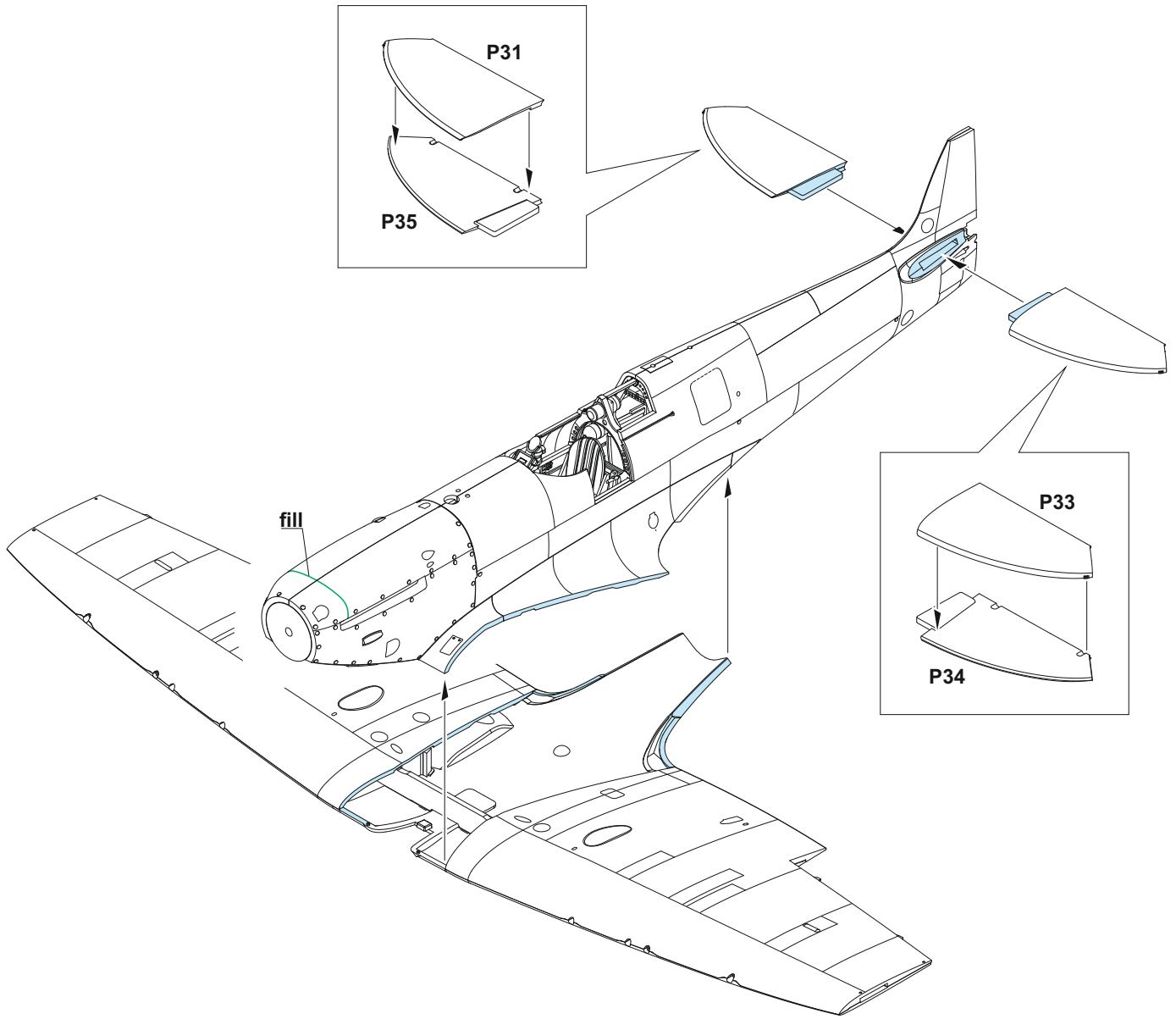

**GLUE PARTS P40 & P41
ONE BY ONE**

P30 - MARKINGS F; G ONLY

P27 ? P30

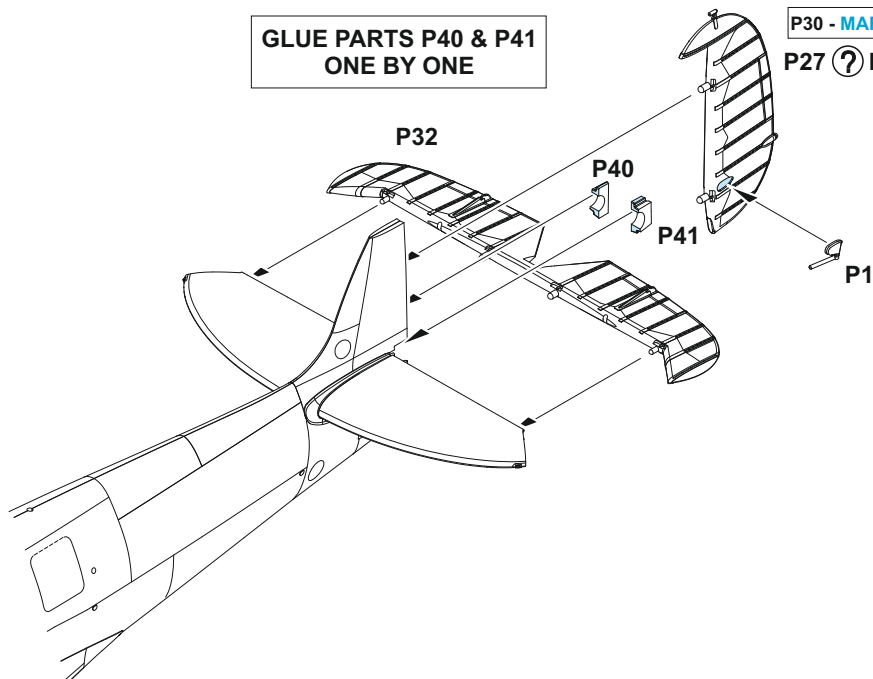

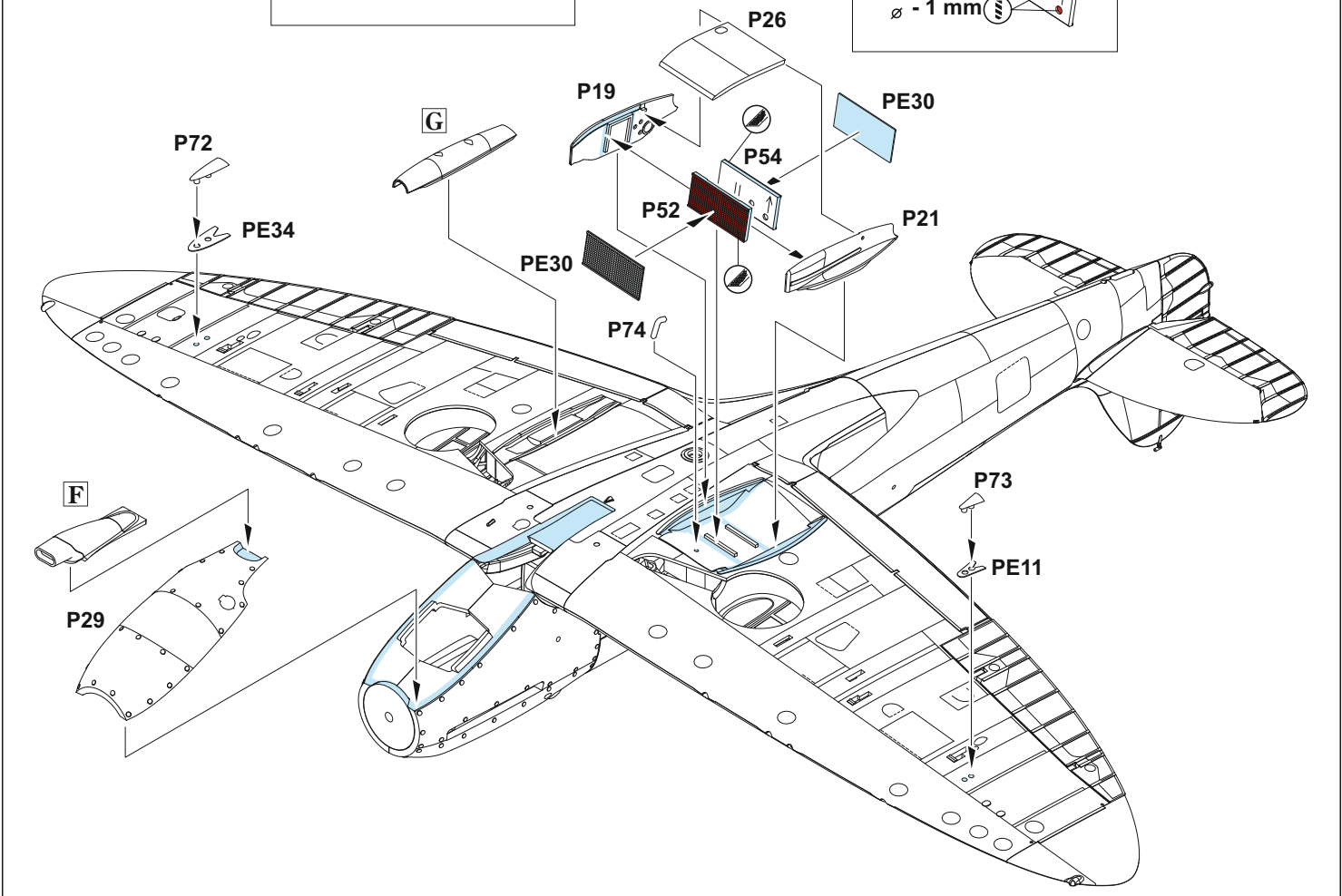
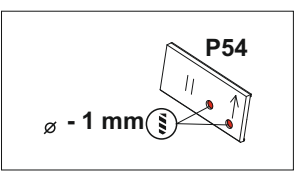
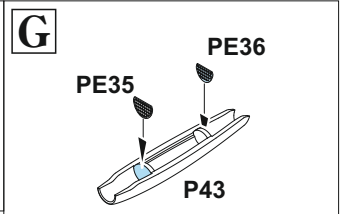
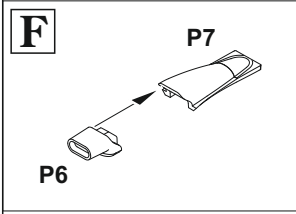
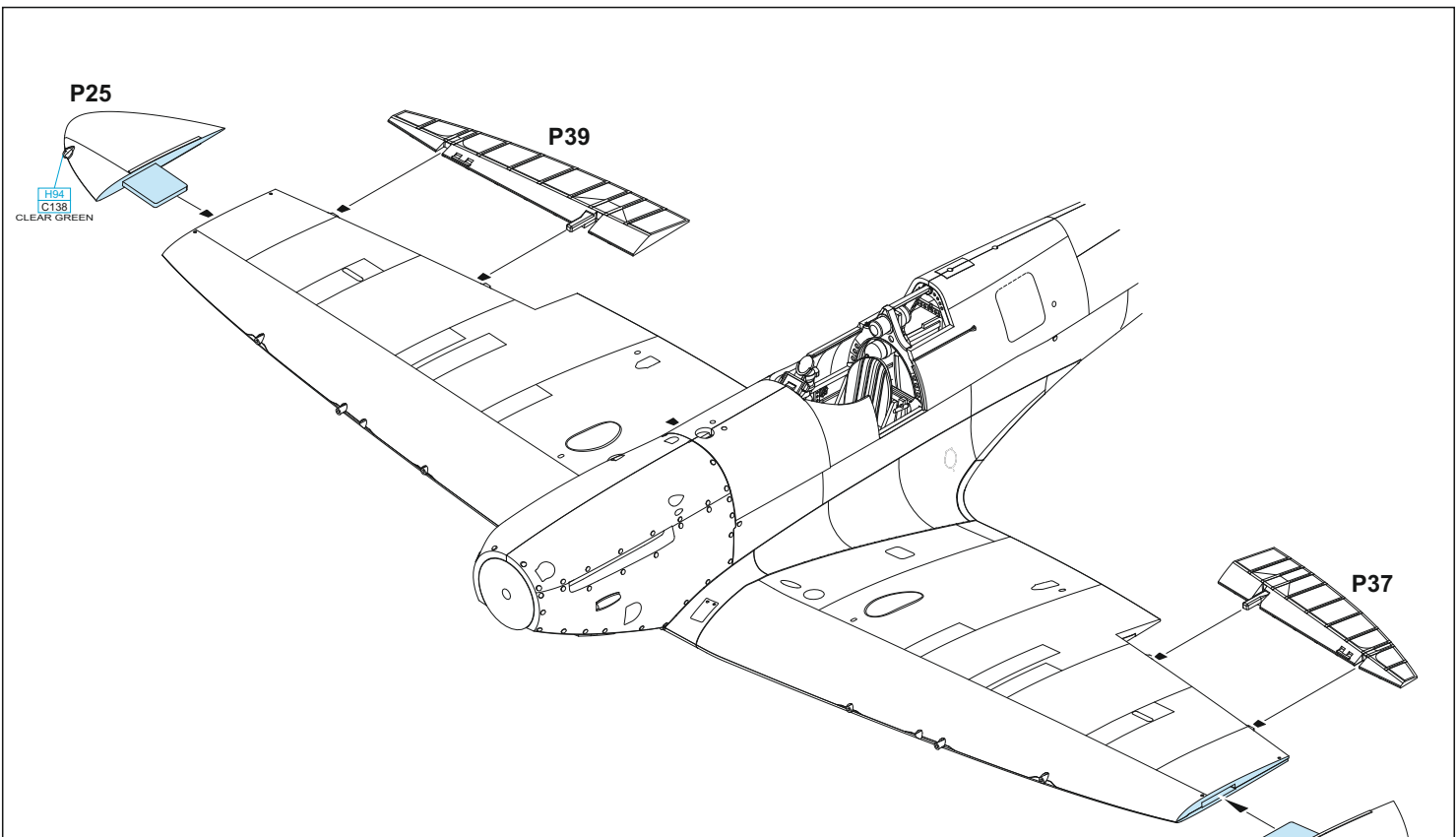

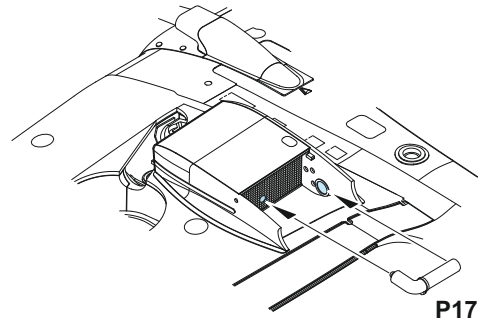
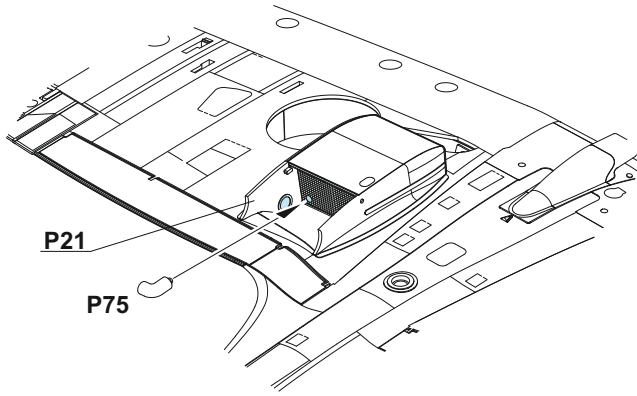

2 pcs.

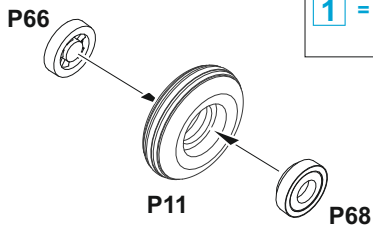
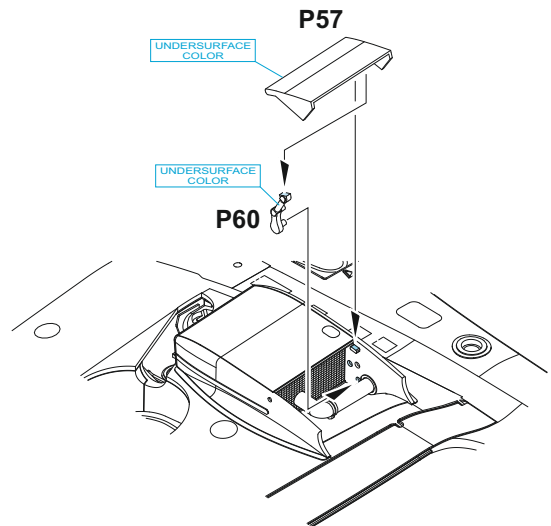
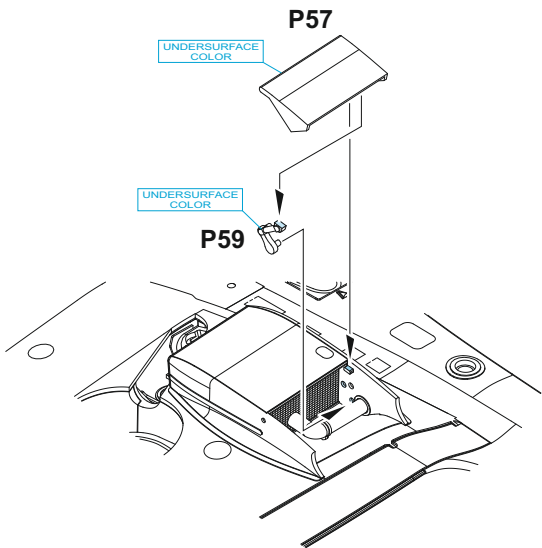
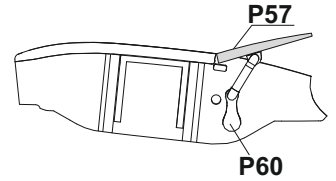
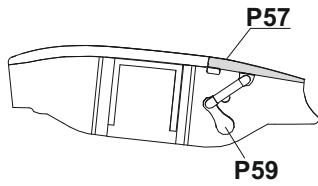
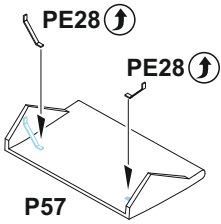

1 =

H8	C8	SILVER
----	----	--------

 - MARKINGS **A; B; C; D; F; G**

H12	MMP	C33	047	port side	FLAT BLACK
-----	-----	-----	-----	-----------	------------

H11	MMP	C62	001	starboard	FLAT WHITE
-----	-----	-----	-----	-----------	------------

 - MARKING **E**

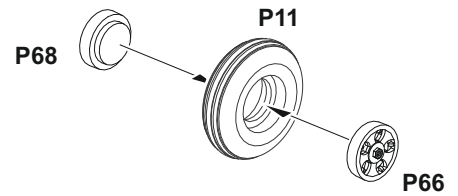

H

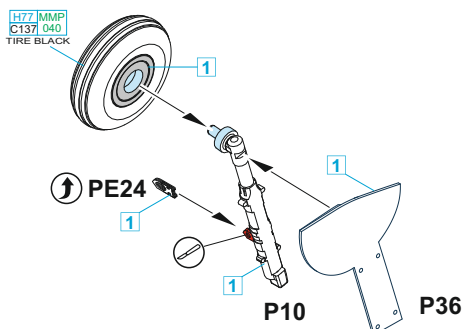

I

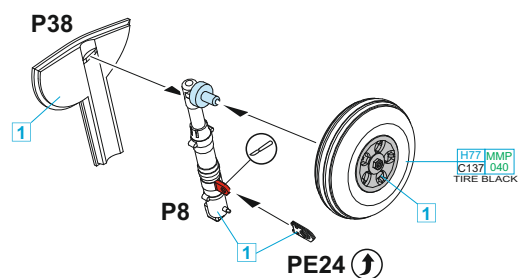

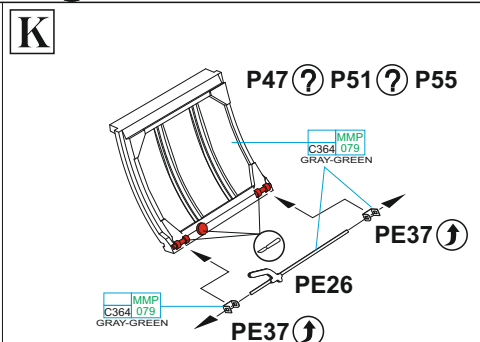
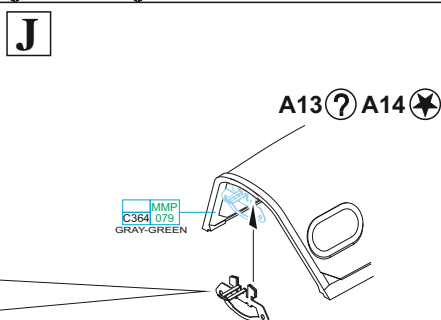
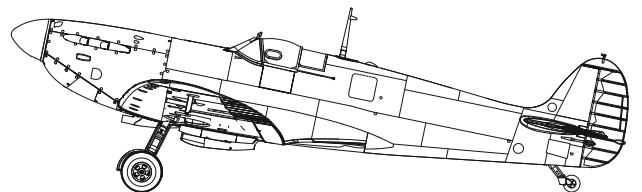
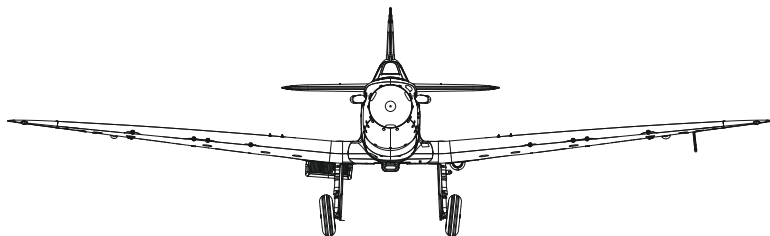
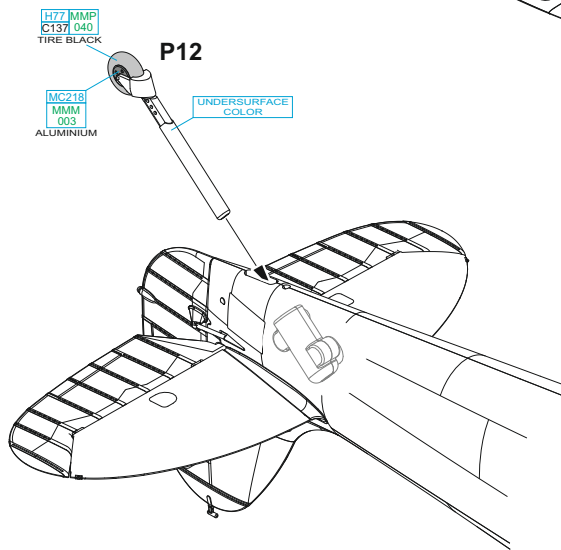
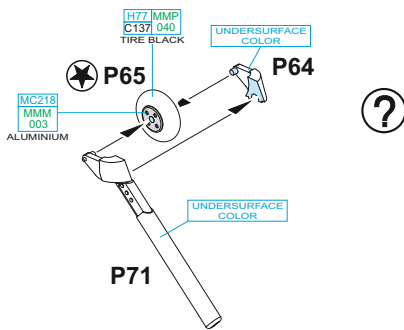
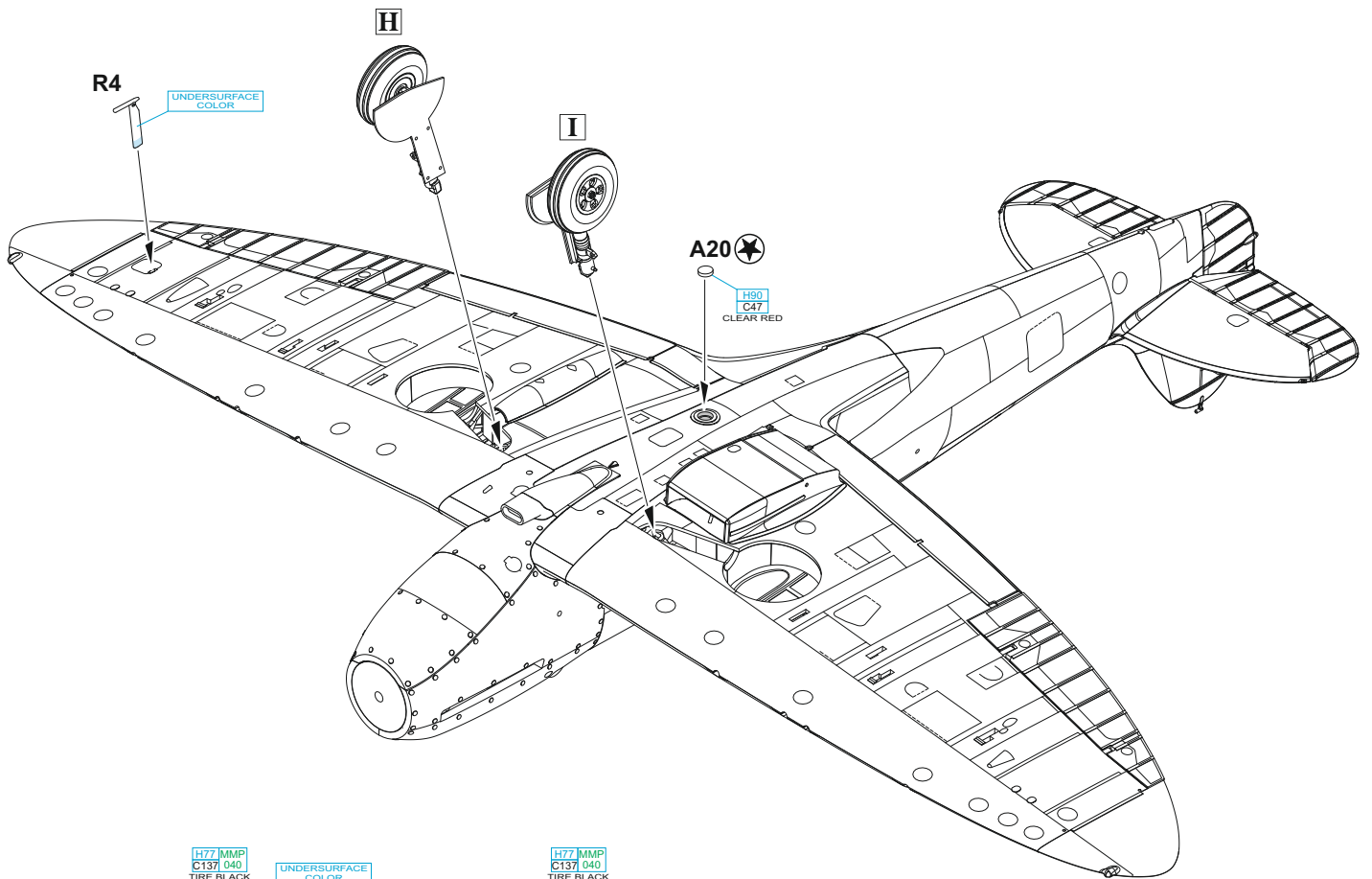

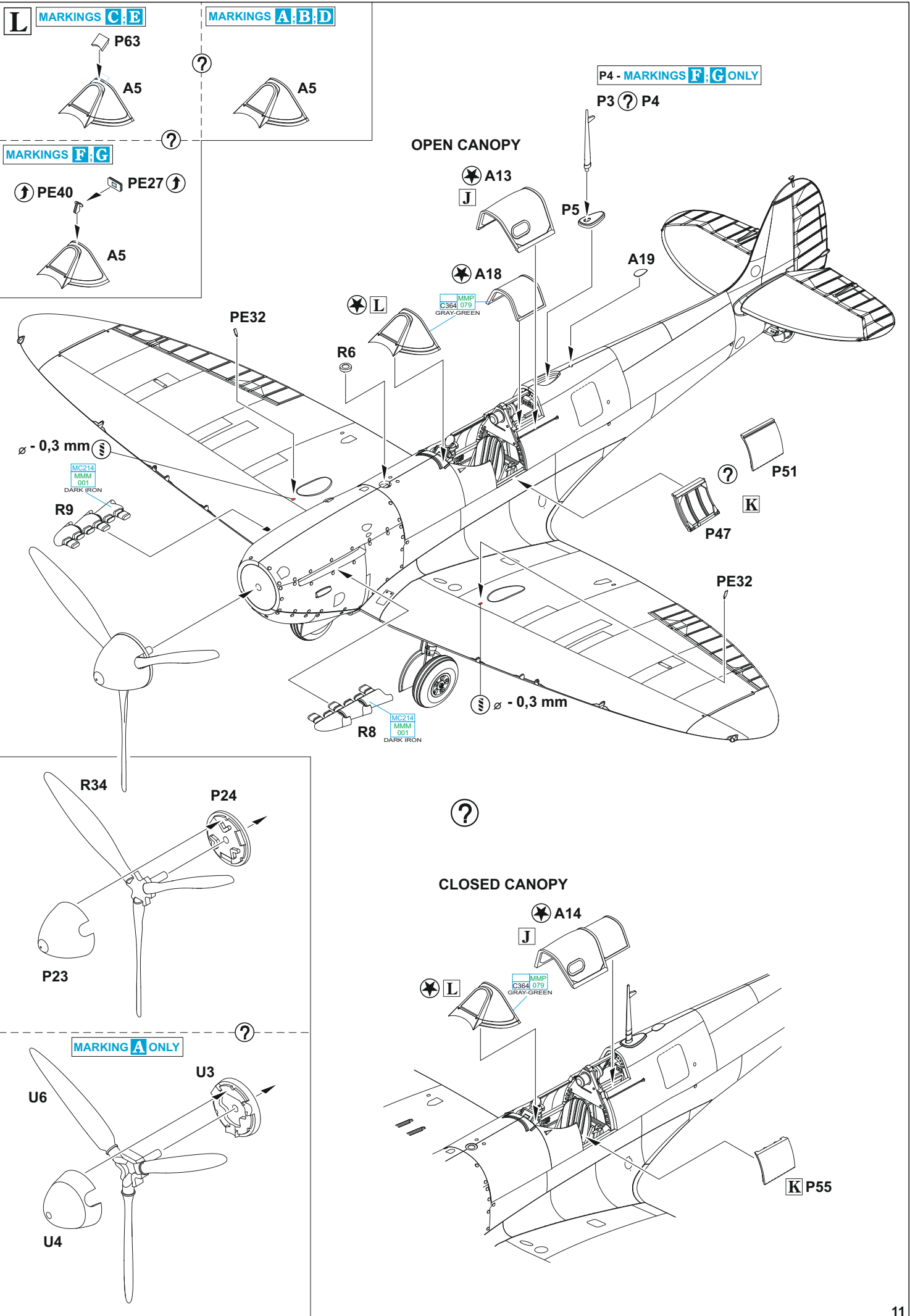

L MARKINGS **C, E**

MARKINGS **A, B, D**

P4 - MARKINGS F, G ONLY

MARKINGS **F, G**

OPEN CANOPY

CLOSED CANOPY

MARKING **A ONLY**

MARKINGS A B C D E

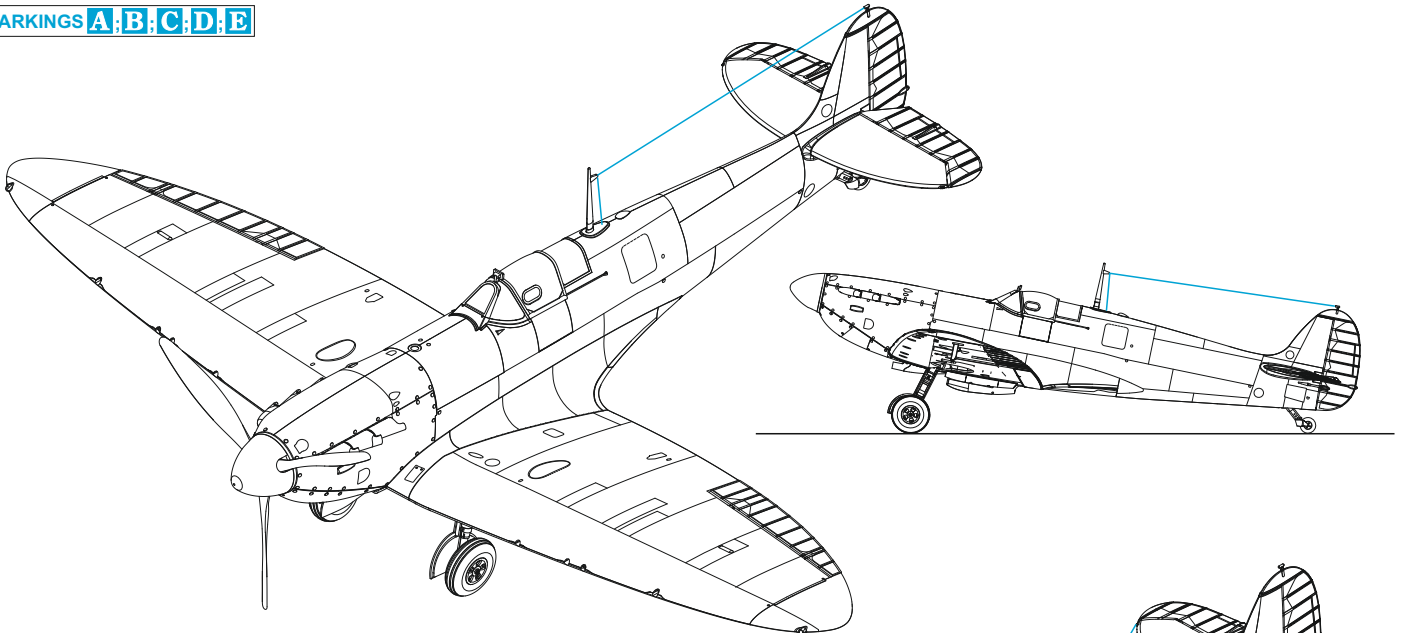

MARKINGS F, G

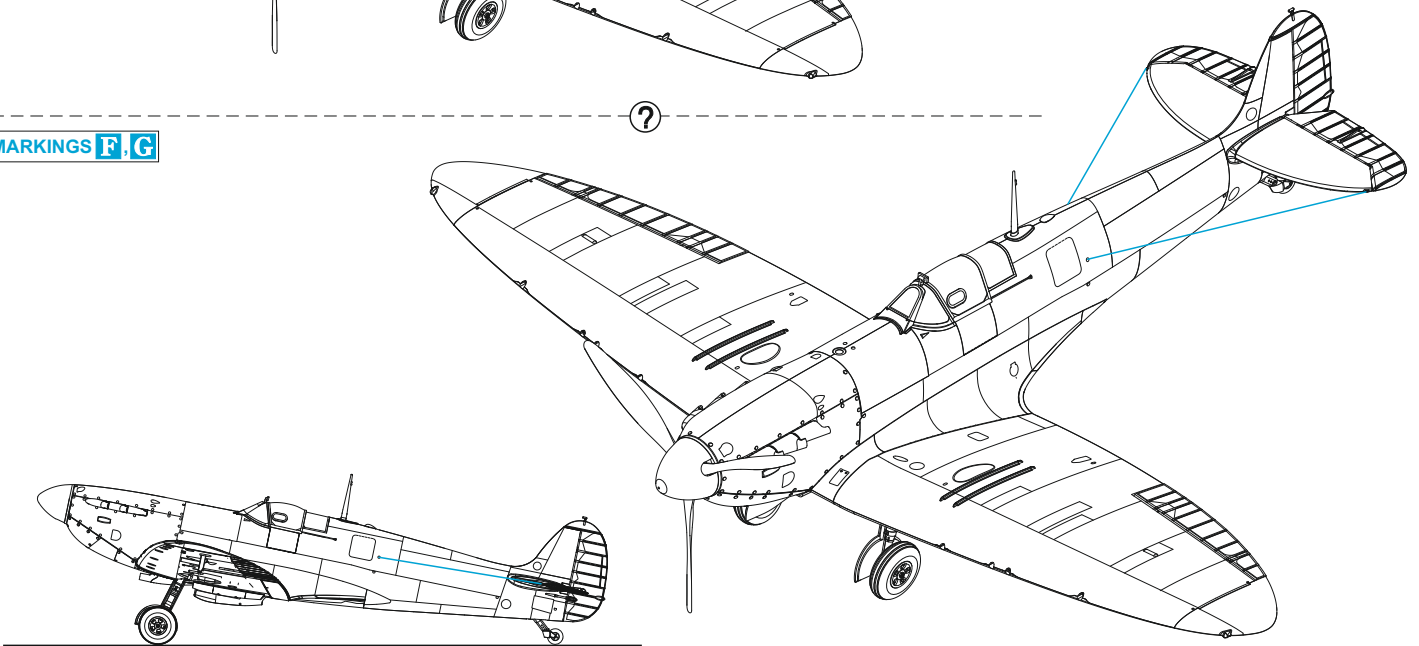

eduard
MASK

82151

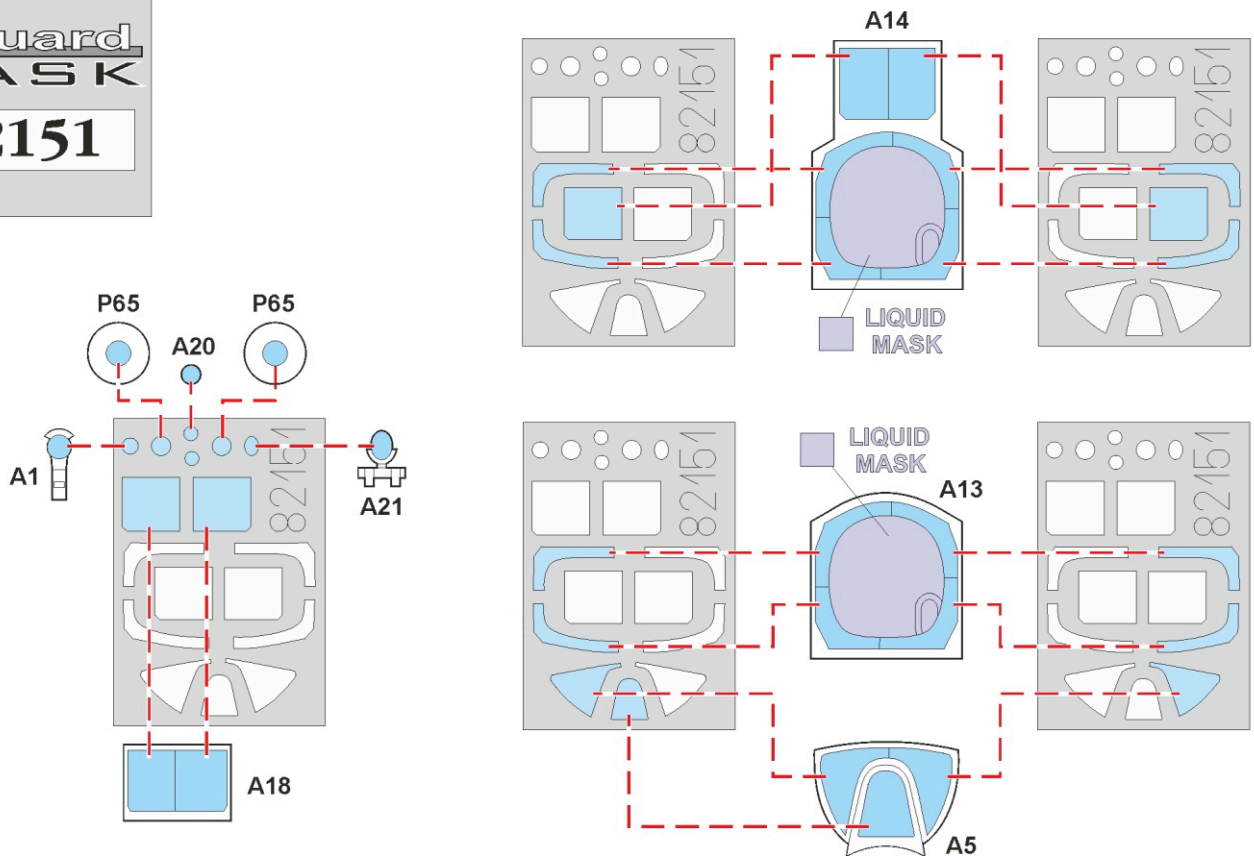

A R6709, flown by P/O Colin Falkland Gray, RNZAF, No. 54 Squadron, RAF Hornchurch, United Kingdom, March 1940

Flown by P/O Colin Falkland Gray, R6709, coded KL-T, wore the standard RAF Temperate Land Scheme of Dark Green and Dark Earth on the upper surfaces, and White/Night lower surfaces. Type A fuselage roundels, Type B upper wing roundels and Mixed Grey code letters were carried. No roundels on the bottom surfaces. Note the Rotol constant speed propeller. The aircraft was equipped with an older TR.9B radio, with the wire antenna stretching between the antenna mast and fin tip. The antenna mast isolator was a little bit shorter while using the newer TR.9D radio. There was no rear mirror or head armor yet installed. Colin Gray got his first kill, a Bf 109E, on May 25th, 1940, while escorting a Swordfish formation to bomb Gravelines. By early September he had claimed 14½ kills. He finished the war as Wing Commander with 27 kills, two shared, six probable and four shared probable kills. This score makes him the top scoring New Zealand fighter ace of the Second World War.

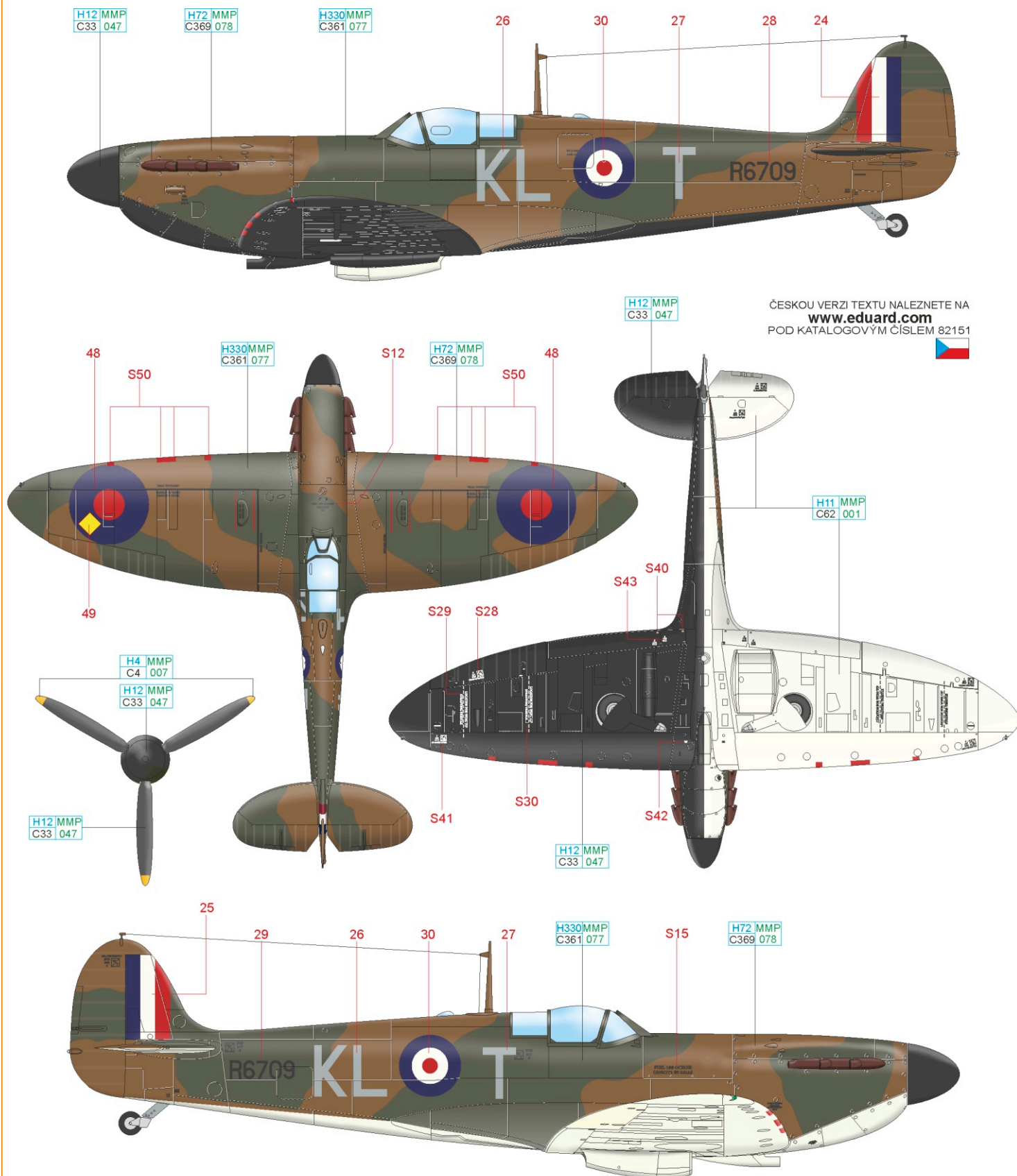

WHITE	H11 MMP C62 001	YELLOW	H4 MMP C4 007	DARK EARTH	H72 MMP C369 078	DARK GREEN	H330MMP C361 077	BLACK	H12 MMP C33 047
-------	-----------------	--------	---------------	------------	------------------	------------	------------------	-------	-----------------

C R6690, flown by P/O John C. Dundas, No. 609 Squadron, RAF Middle Wallop / RAF Warmwell, United Kingdom, August 13th, 1940

It is believed that this aircraft, serialled R6690 and coded PR-A, was flown by F/O John Dundas when he shot down a Ju 87B of 5./StG 2 west of Portland on August 13th, 1940. While attacking another Stuka, Dundas was hit by defensive fire from the rear gunner, crippling the oil system of his engine, forcing him down at Warmwell Aerodrome. The aircraft was written off. Although the AM directive to paint blue/white/red roundels on the bottom surface of wings was issued already on August 11th, No. 609 Squadron hadn't put the order into practice as of the middle of August. The squadron's aircraft wore the individual letter, in this case A, painted in black on the bottom nose panel, which was painted in a light color, probably white. It is not certain if the rear-view mirror was installed at this time, but it is unlikely. The aircraft was equipped with a TR.9D radio with the wire antenna stretched between the antenna mast and the fin. The IFF device is not yet installed, and so no aerial wires are stretched between the fuselage sides and the horizontal tail.

H12 MMP C33 047
H330MMP C361 077
H72 MMP C369 078

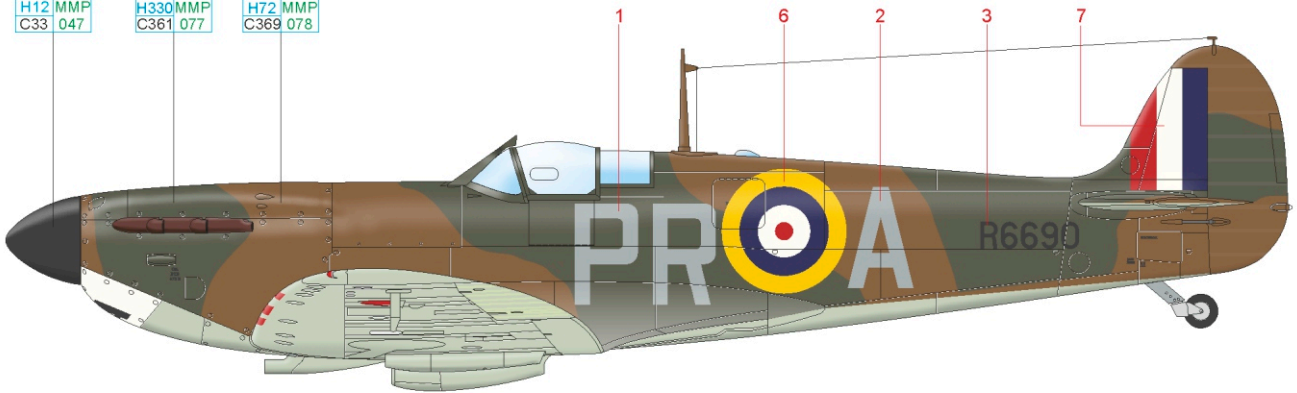

ČESKOU VERZI TEXTU NALEZNETE NA
www.eduard.com
POD KATALOGOVÝM ČÍSLEM 82151

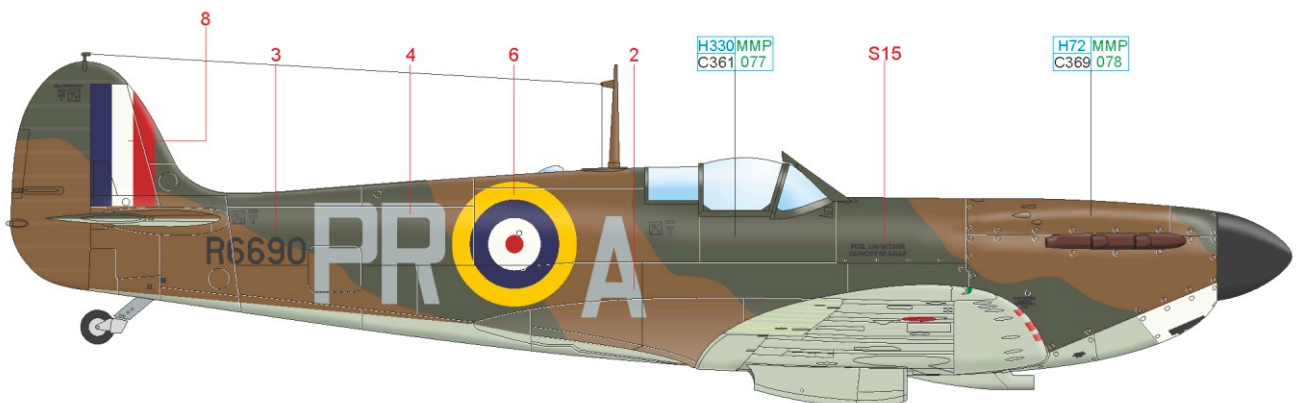
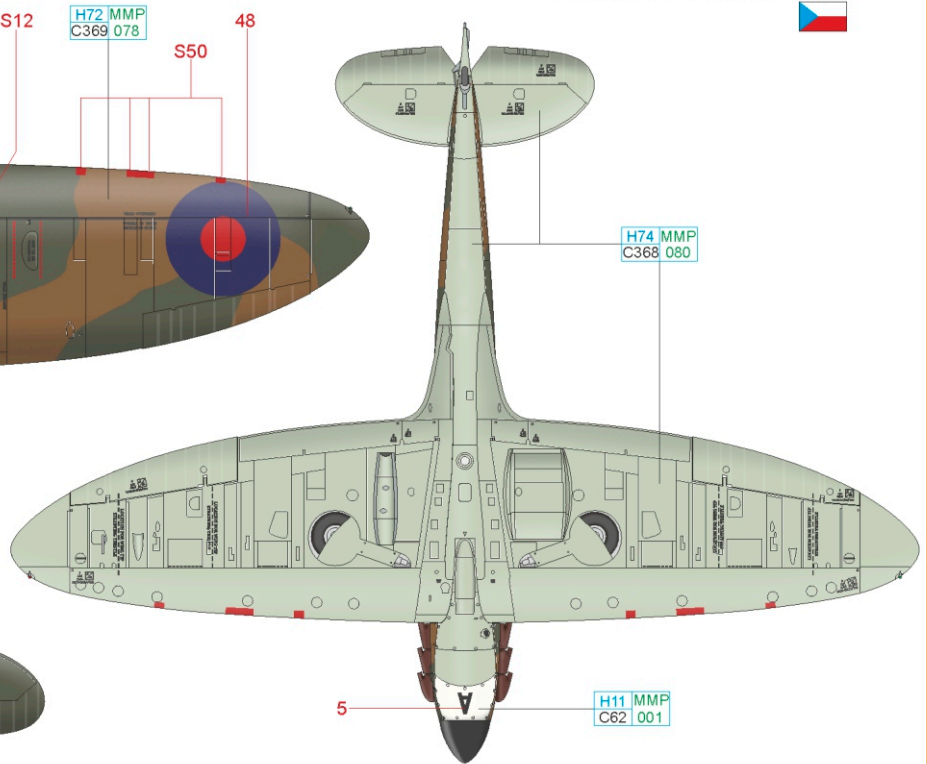
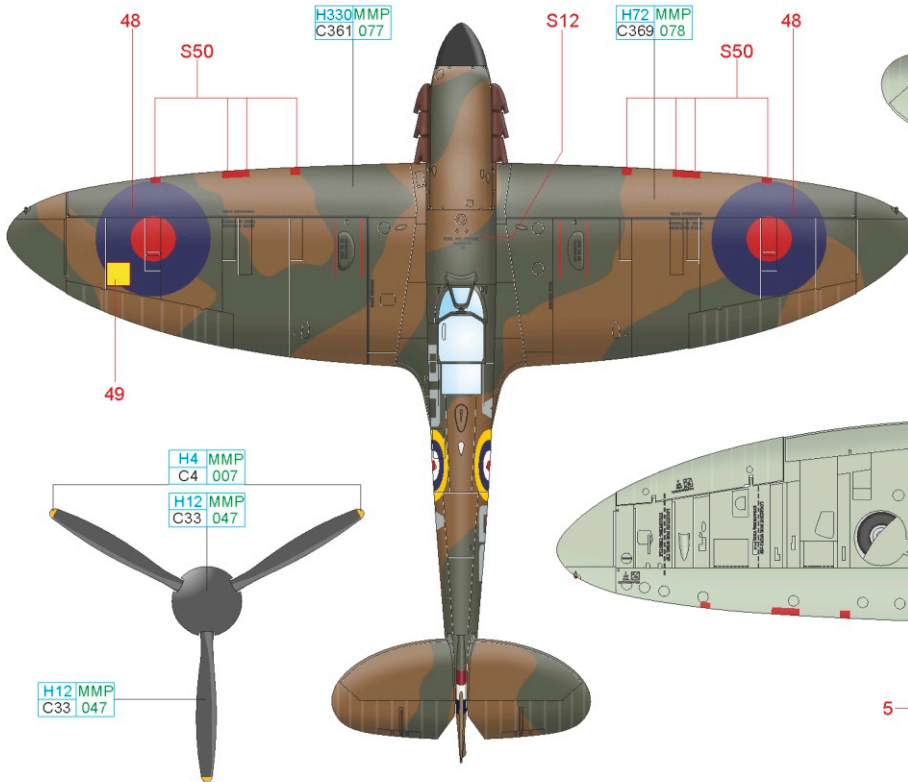

WHITE H11 MMP C62 001 SKY H74 MMP C368 080 YELLOW H4 MMP C4 007 DARK EARTH H72 MMP C369 078 DARK GREEN H330MMP C361 077 BLACK H12 MMP C33 047

D R6835, flown by F/O Brian J. Carbury, No. 603 Squadron, RAF Hornchurch, United Kingdom, late August 1940

Spitfire R6835 XT-W was flown by a New Zealander named Brian J. Carbury, who shot down two Bf 109Es on August 27th, 1940, when No. 603 Squadron arrived at Hornchurch to replace the battle-weary No. 65 Squadron. He scored 15½ kills during the Battle of Britain. On August 31st, 1940, he shot down five enemy aircraft over the span of three sorties, becoming one of two RAF 'Ace of the Day' pilots able to claim that status during the BoB. His aircraft carried the standard RAF Temperate Land Scheme consisting of Sky bottom surfaces. The blue/white/red roundels painted on the bottom surfaces were mandated by the Air Ministry on August 11th, 1940. The aircraft was equipped with a TR.9D radio with the wire antenna stretching between the antenna mast and fin. The IFF device is not yet installed, explaining the absence of the associated aerial wires between the fuselage sides and the horizontal tail. No rear-view mirror was carried yet, nor was the head armor plating in the cockpit.

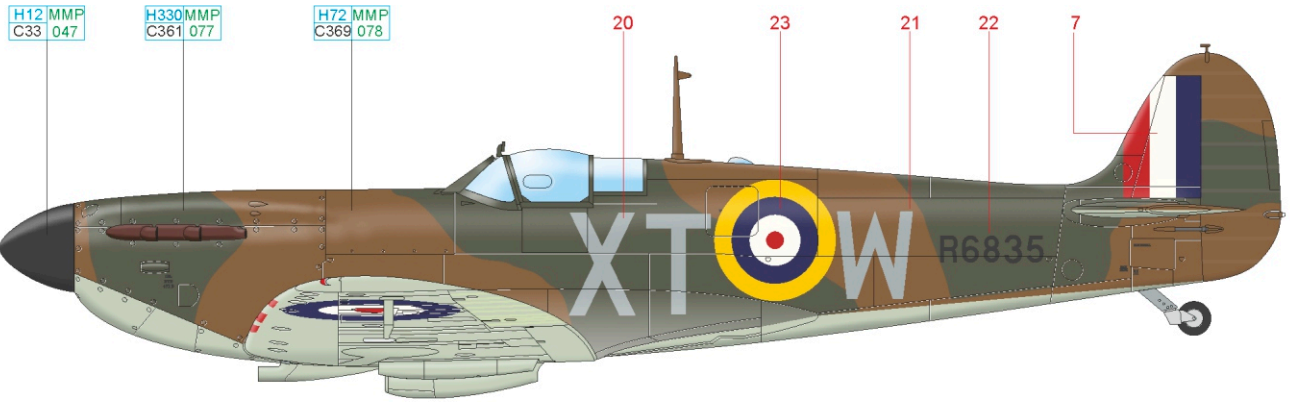

ČESKOU VERZI TEXTU NALEZNETE NA www.eduard.com
 POD KATALOGOVÝM ČÍSLEM 82151

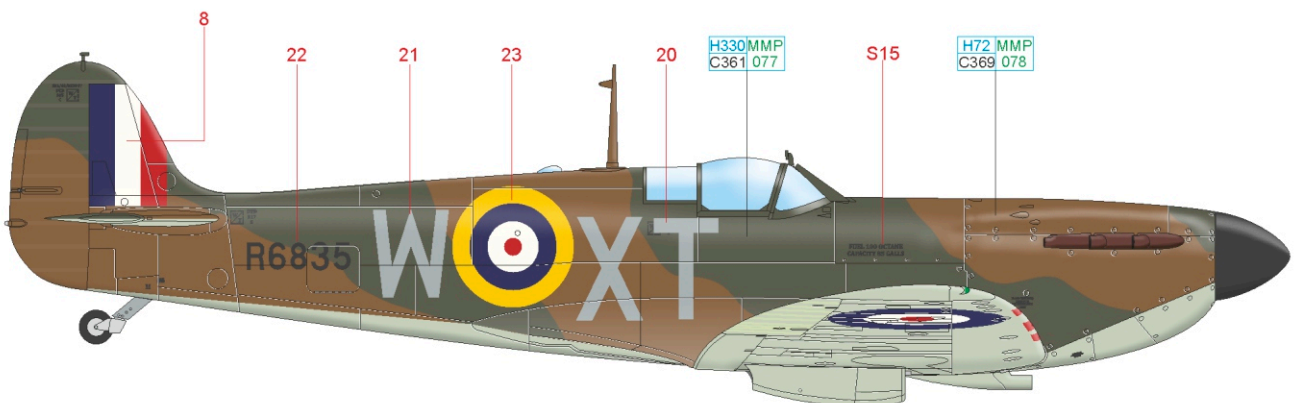
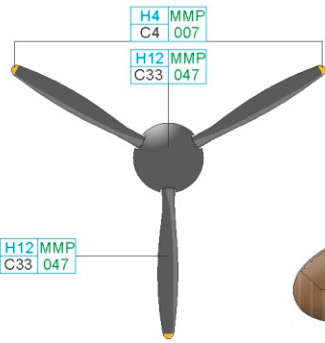
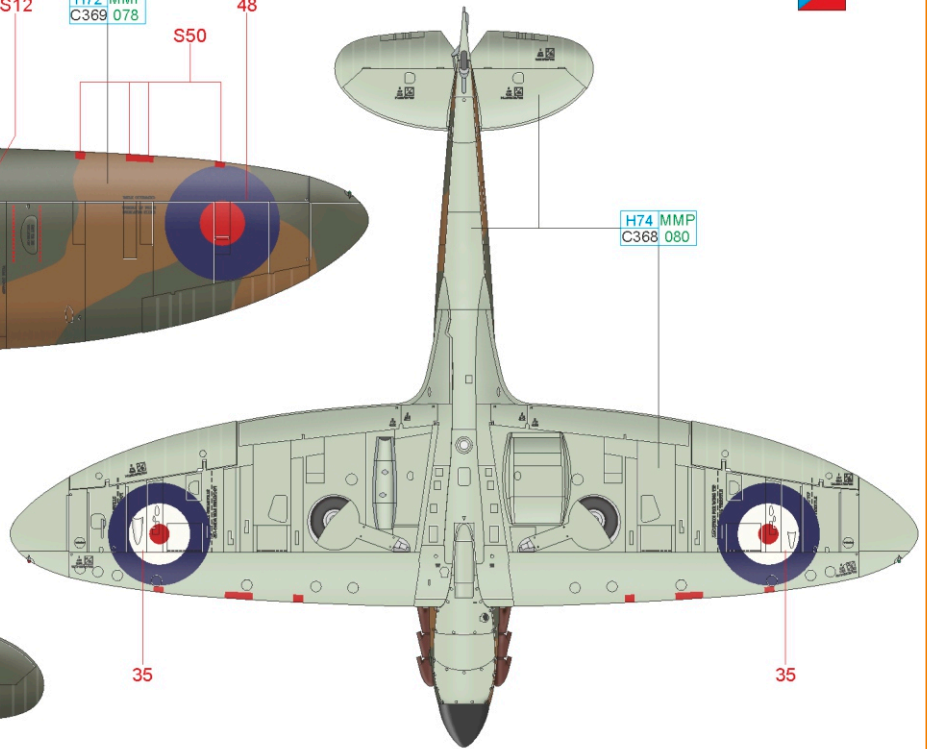
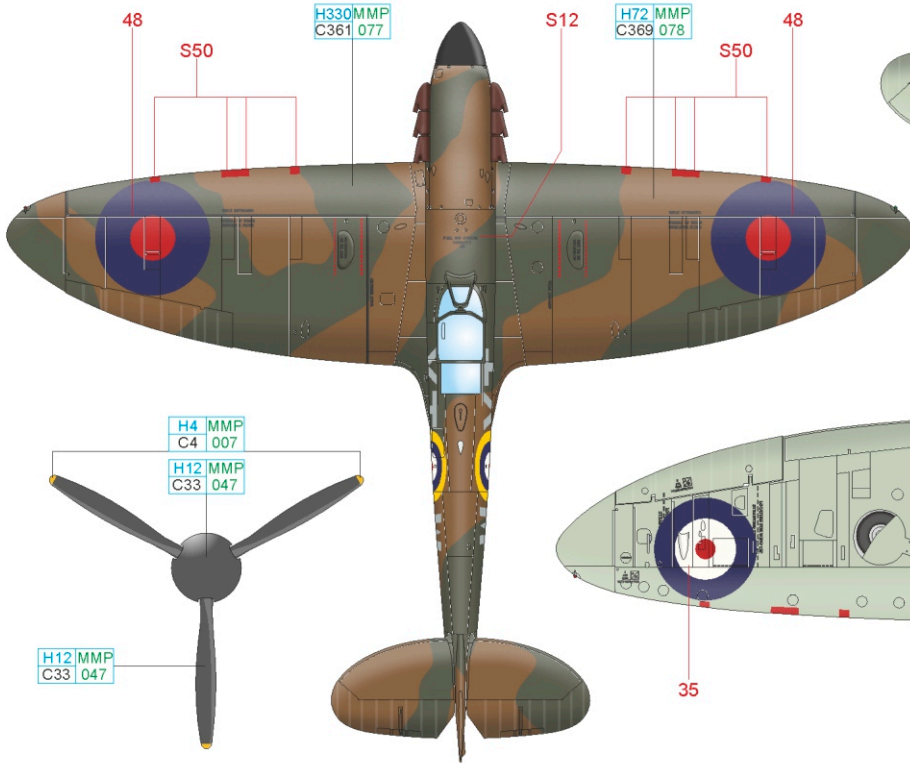

- SKY H74 MMP C368 080
- YELLOW H4 MMP C4 007
- DARK EARTH H72 MMP C369 078
- DARK GREEN H330MMP C361 077
- BLACK H12 MMP C33 047

E P9386, flown by S/Ldr Brian J. Lane, No. 19 Squadron, RAF Fowlmere, United Kingdom, September 1940

Spitfire P9386 arrived from No.7 OTU at Fowlmere as a replacement aircraft for the problem plagued, cannon armed Spitfire Mk.Ib on September 3rd, 1940. The yellow spinner appears to be the remnants of the OTU's markings. The aircraft is an example of the final Battle of Britain camouflage and marking practice, with the small diameter version of the bottom surface roundels located near the wing tips. No stenciling is seen on the bottom surfaces. Note the aerial wire between the antenna mast and the fin. The IFF device is not yet carried. No hot air gun heating system under the wing tips could be seen, so it is possible that an electrical gun heating system was installed. Although the aircraft is referred to as being 'somewhat poorly maintained', it is also mentioned as a favorite of two famous members of No. 19 Squadron, F/Lt Walter Lawson and S/Ldr Brian Lane, who claimed a Stab II./ZG 2 Bf 110 on September 7th, and another two Bf 110s on September 11th, while Lawson claimed a Bf 110 on September 9th, 1940.

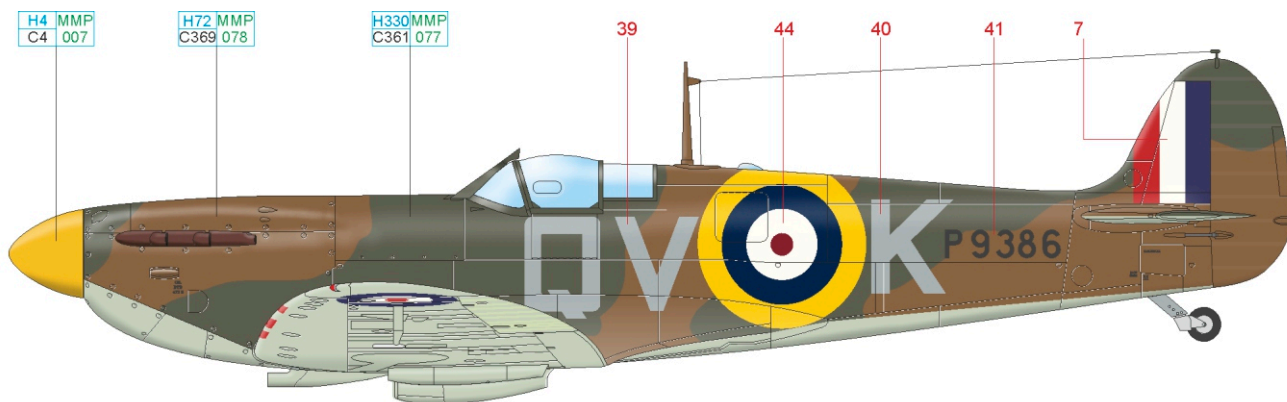

ČESKOU VERZI TEXTU NALEZNETE NA
www.eduard.com
 POD KATALOGOVÝM ČÍSLEM 82151

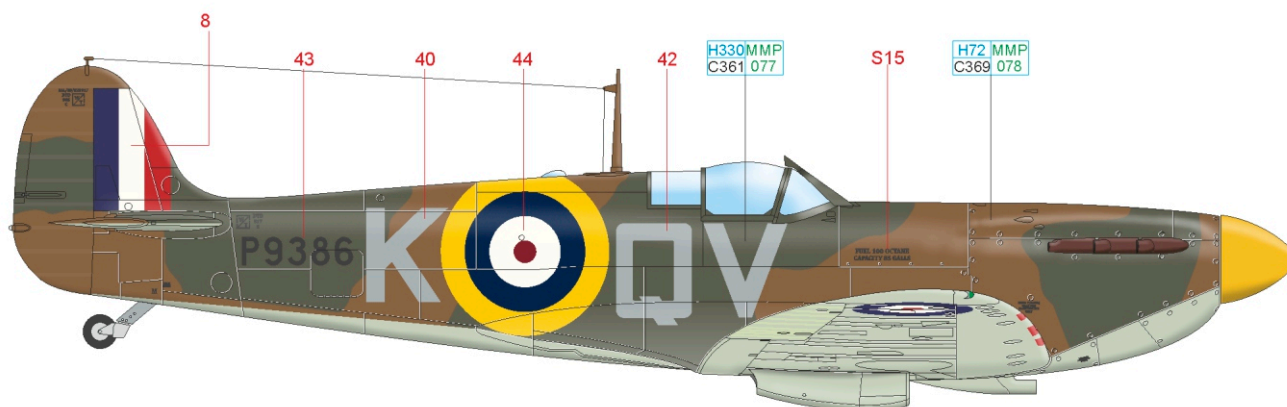
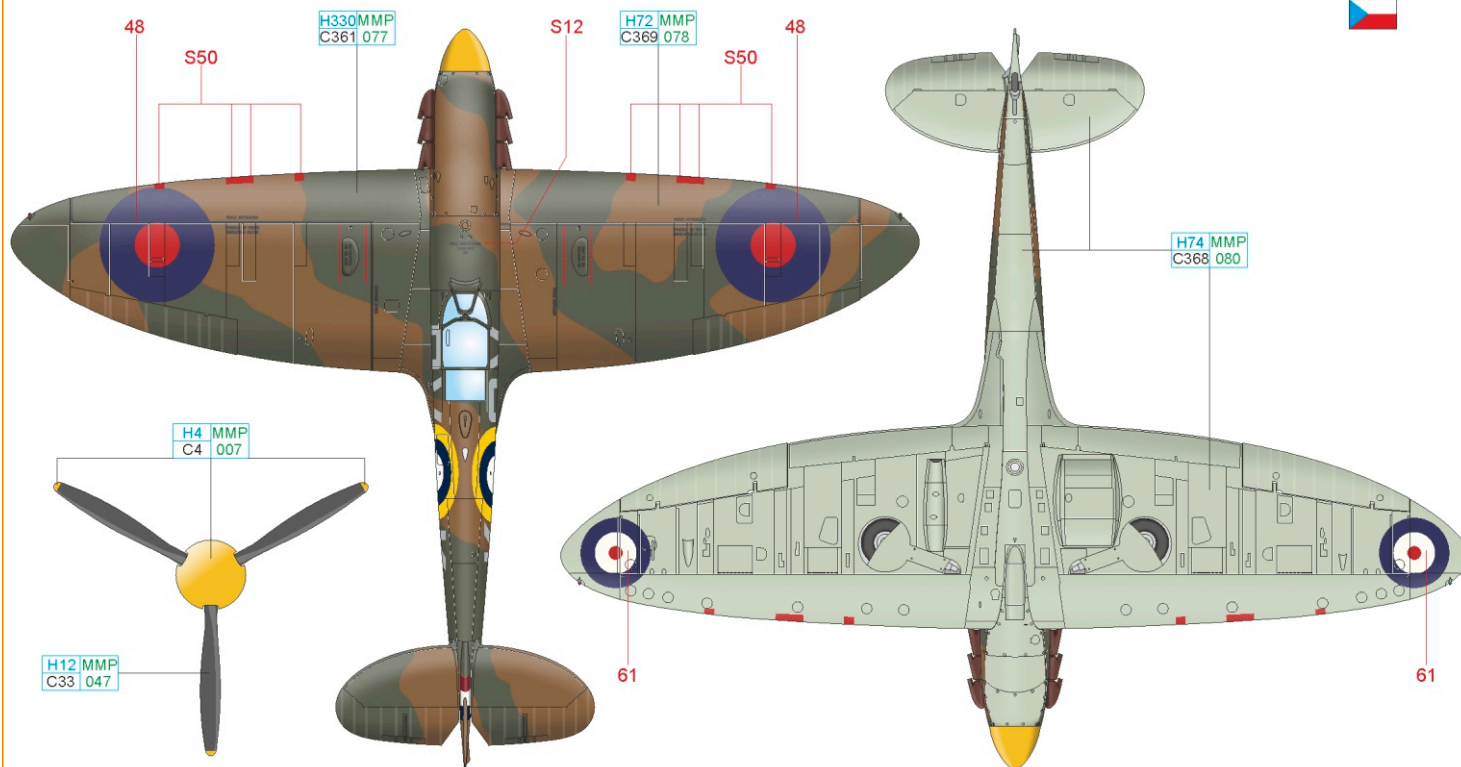

SKY	H74 MMP C368 080	YELLOW	H4 MMP C4 007	DARK EARTH	H72 MMP C369 078	DARK GREEN	H330MMP C361 077	BLACK	H12 MMP C33 047
-----	------------------	--------	---------------	------------	------------------	------------	------------------	-------	-----------------

F X4253, flown by P/O Wilfrid G. Duncan Smith, No. 611 Squadron, RAF Hornchurch, United Kingdom, February 1941

This Spitfire Mk.Ia, serialled X4253, illustrates the camouflage scheme and markings of Fighter Command aircraft in late 1940 and early 1941. The black painted (Night) left wing was ordered by the Air Ministry on November 27th, 1940. The left wing roundel was then appropriately outlined in yellow. To improve recognition of friendly aircraft, an 18-inch wide Sky Blue fuselage band was added ahead of the tail, and the spinner was painted in the same colour. This paint was usually a little bit more blue than the standard under surface Sky. Some sources name this colour 'Air Ministry Blue'. This aircraft was equipped with the new VHF TR.1133 radio and, as such, there is no aerial between the antenna mast and the fin tip. The R.3002 IFF device was carried, indicated by the two associated wire aerials stretching between the fuselage sides and the leading edges of the horizontal tail. Note the external rearview mirror, and the armor plating behind the pilot's head was installed. This aircraft was flown by future ace P/O Wilfrid G. Duncan Smith, who joined No. 611 Squadron at RAF Hornchurch in October 1940 with the rank of Pilot Officer.

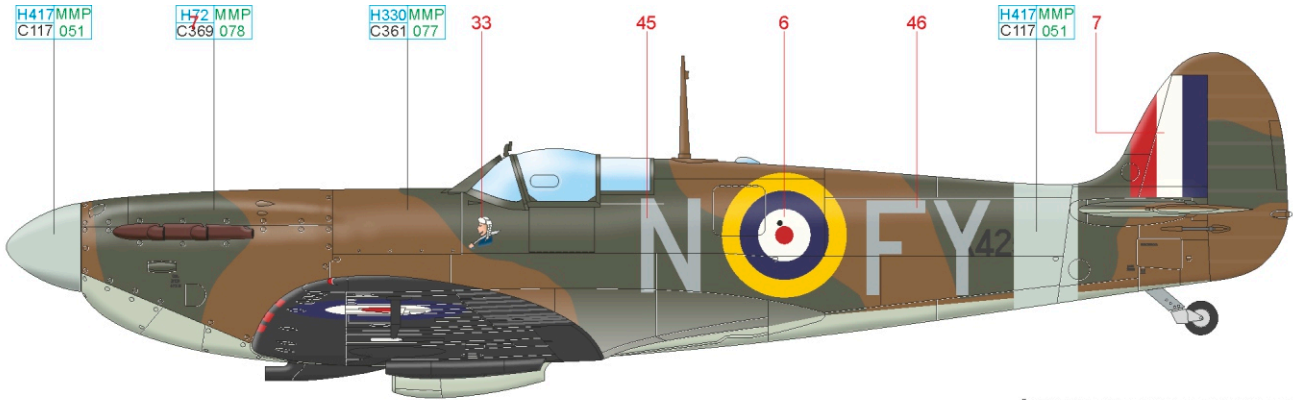

ČESKOU VERZI TEXTU NALEZNETE NA
www.eduard.com
 POD KATALOGOVÝM ČÍSLEM 82151

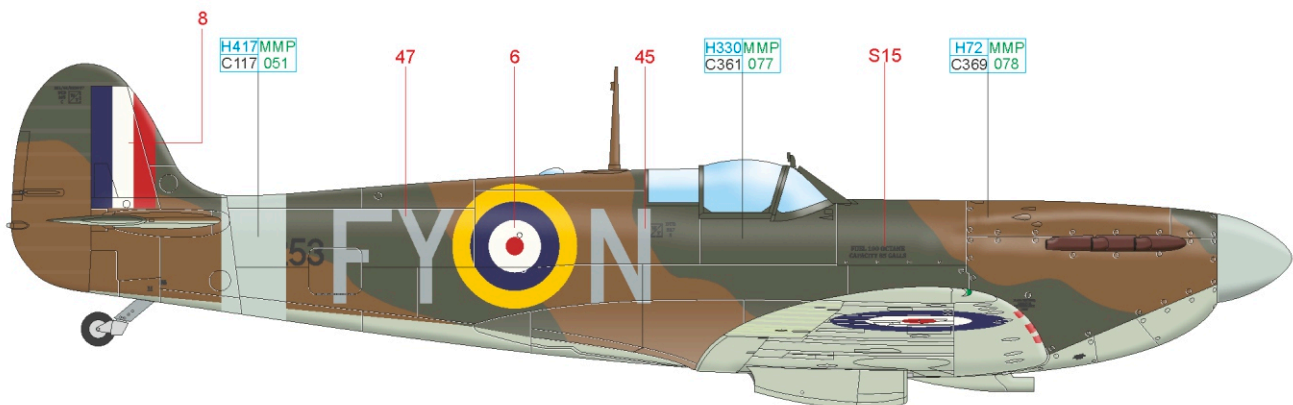
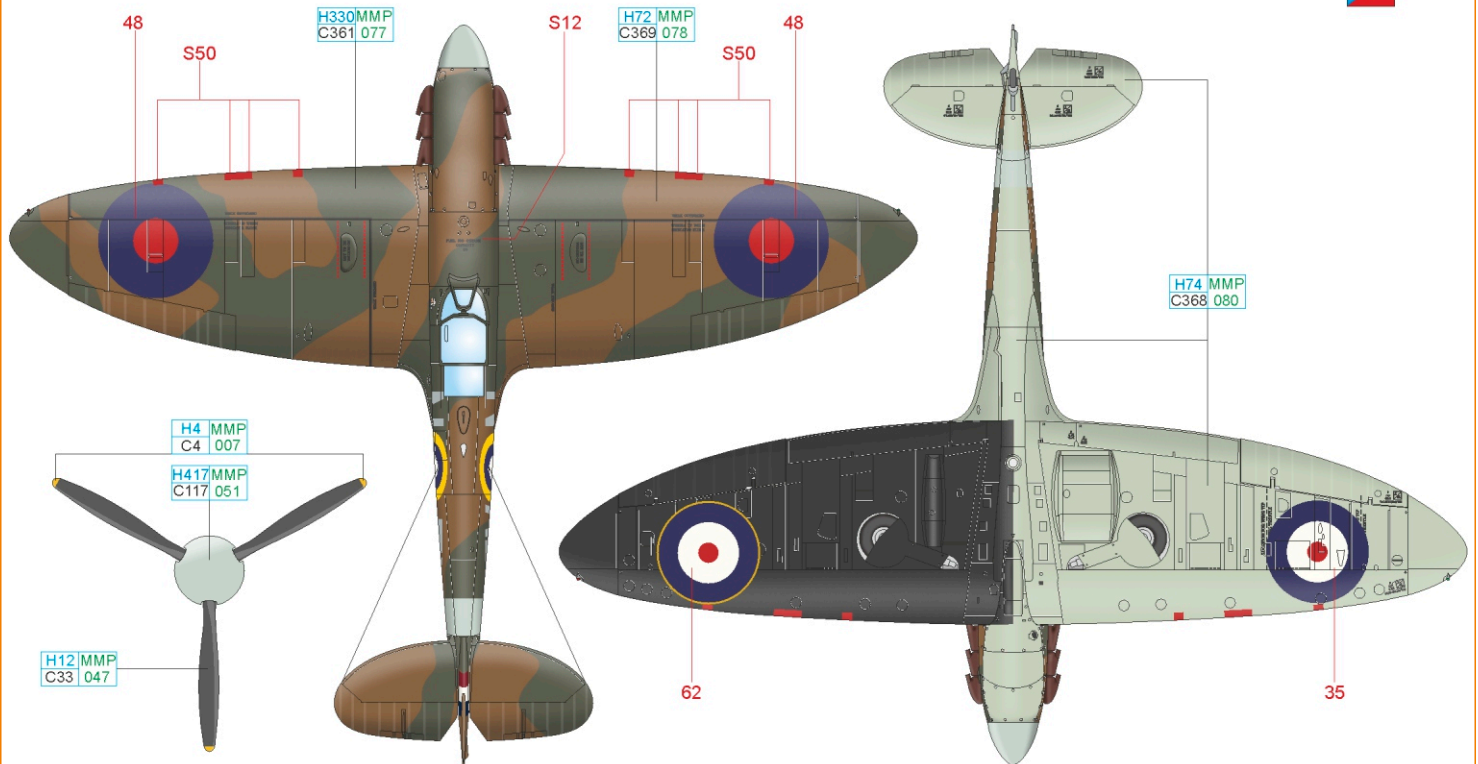

SKY	H74 MMP C368 080	YELLOW	H4 MMP C4 007	LIGHT BLUEGREEN	H417MMP C117 051	DARK EARTH	H72 MMP C369 078	DARK GREEN	H330MMP C361 077	BLACK	H12 MMP C33 047
-----	---------------------	--------	------------------	-----------------	---------------------	------------	---------------------	------------	---------------------	-------	--------------------

G X4828, flown by F/Lt Wojciech Kolaczowski, No. 303 Squadron, RAF Speke, United Kingdom, September 1941

Spitfire Mk.Ia, carrying the serial X4828 and RF-K code, belonged to No. 303 (Polish) Squadron and is representative of the new Day Fighter Scheme, introduced on August 19th, 1941. From that date, RAF day fighters were painted in Dark Green and Ocean Grey on the upper surfaces and Medium Sea Grey on the lower surfaces. The aircraft letters were by then changed to Sky, and the fuselage band and spinner remained in the same colour. Note the thin dark border around the letters and the stencil data inscriptions painted on the Ocean Grey surfaces, which are believed to be remnants of the original Dark Earth layer. No. 303 Squadron was moved to RAF Speke from RAF Norholt on July 17th, 1941, leaving their Spitfire Mk.IIb aircraft behind to receive old war weary Mk.Ia's for training purposes. RF-K was flown by A Flight leader F/Lt Kolaczowski, who was later No. 303 Squadron Leader from November 21st, 1941 to May 7th, 1942. The name 'Vojtek' is Kolaczowski's nickname and the name 'Krysia' was the nickname of his girlfriend Kristina. It is not known with certainty if these inscriptions were painted on the right side as well. No. 303 Squadron returned to Norholt on October 7th, 1941 to be re-armed with the new Spitfire Mk.Vb and engaged the new German Fw 190As in intense combat on the other side of the Channel.

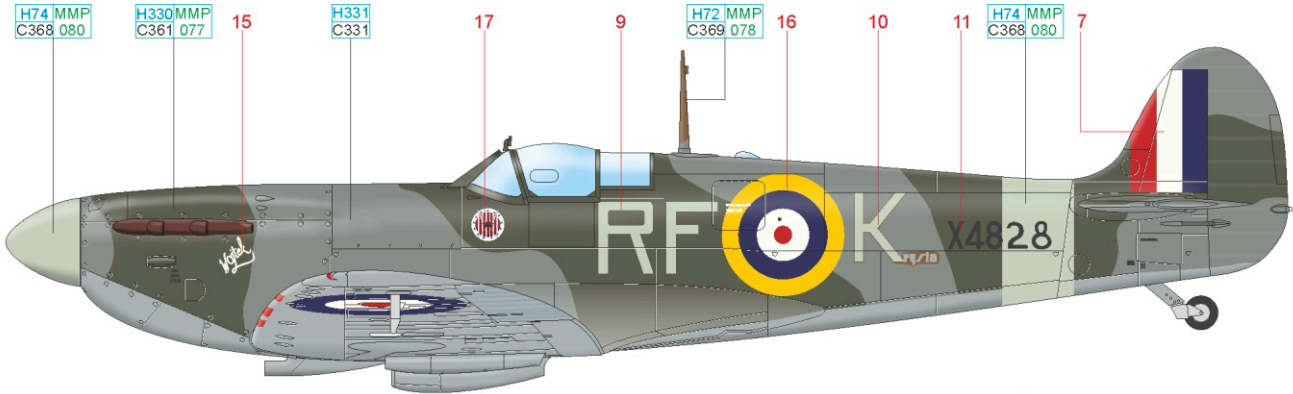

ČESKOU VERZI TEXTU NALEZNETE NA
www.eduard.com
POD KATALOGOVÝM ČÍSLEM 82151

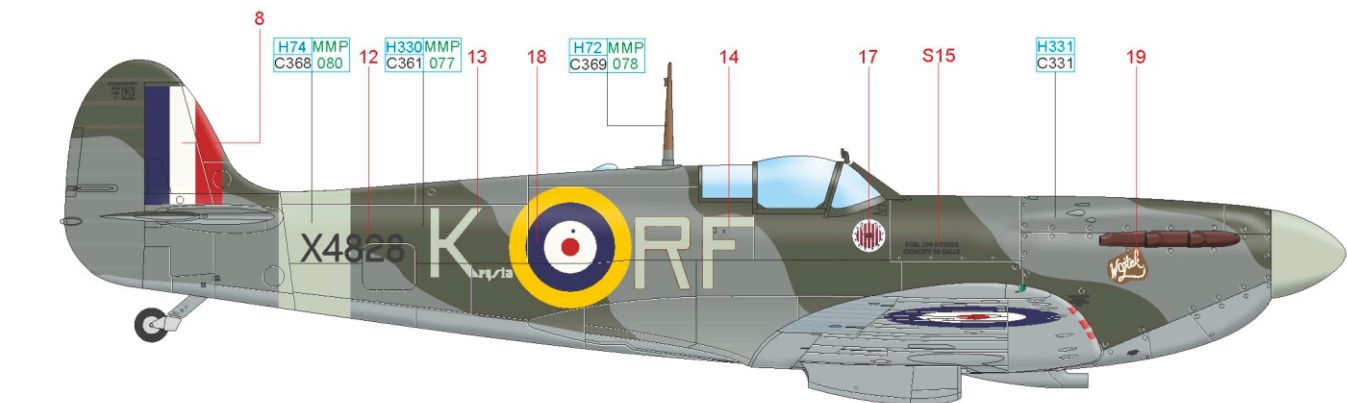
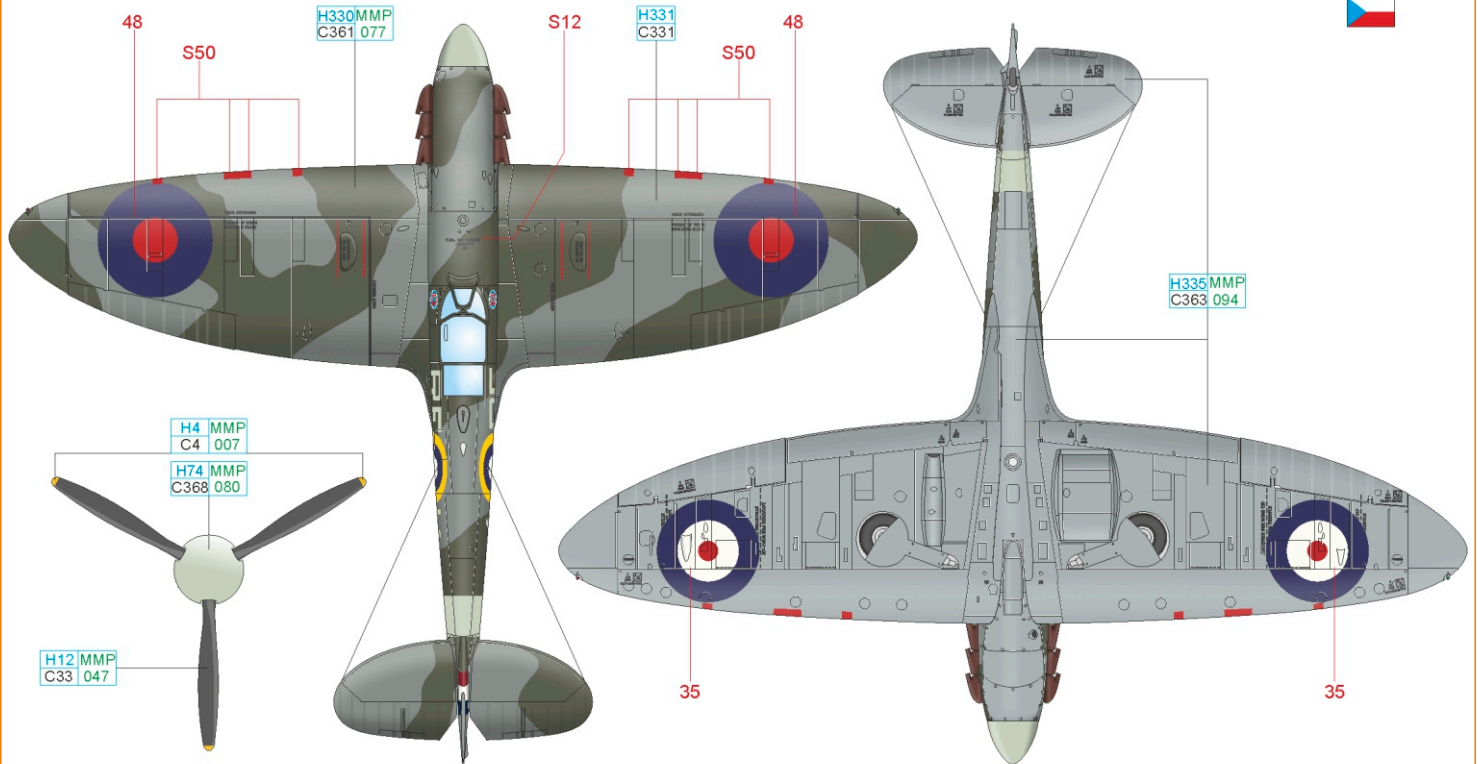

SKY	H74 MMP C368 080	YELLOW	H4 MMP C4 007	MEDIUM SEA GRAY	H335 MMP C363 094	DARK EARTH	H72 MMP C369 078	DARK SEA GRAY	H331 C331	DARK GREEN	H330 MMP C361 077	BLACK	H12 MMP C33 047
-----	---------------------	--------	------------------	--------------------	----------------------	---------------	---------------------	------------------	--------------	---------------	----------------------	-------	--------------------

